

# TeleObserver MR3140

Mobile hybrid digital video recorder



## User manual

Firmware 6.1

This document may not be copied, reproduced, summarised, translated or otherwise reproduced without the express permission of DResearch. It has been compiled to the best knowledge of DResearch. DResearch is not responsible for the consequences of typographical or residual errors relating to the user manual which is only informative in nature.

DResearch retains the right to make amendments to the contents of the user manual without having any duty to inform third parties. Any change made to the product or its associated software not expressly confirmed by DResearch will result in the termination of the operating licence and warranty.

Any company and/or product names are trade names and or legally protected trademarks of the relevant manufacturer.

© **Copyright 2011 DResearch Fahrzeugelektronik GmbH. All rights reserved.**

## CONTENTS

<b>1</b>	<b>General information about DResearch video systems .....</b>	<b>5</b>
1.1	System overview and new functions in this version.....	6
1.2	Scope of delivery.....	7
1.3	Accessories & additional devices.....	7
1.4	Safety advice.....	8
1.5	Warranty.....	9
1.6	Certifications, standards and conformities.....	9
1.7	Scope of use.....	10
1.8	General installation information.....	10
1.9	Temperature range.....	11
1.10	System components and device features.....	12
<b>2</b>	<b>The recording device MR3140 in detail .....</b>	<b>15</b>
2.1	Device description.....	15
2.2	Changing and inserting the removable disk.....	16
2.3	Significance of the status LEDs.....	17
2.4	Device interfaces.....	18
2.4.1	Analogue video inputs 1 ... 4 – connection of analogue CCTV cameras.....	18
2.4.2	LAN Interface – connection of IP network cameras or other devices.....	18
2.4.3	Video Out 1 and 2 – connection of control monitors.....	19
2.4.3.1	Sequential video output and multiviews.....	19
2.4.3.2	Display of information and system events (OSD).....	20
2.4.4	Power supply for the device and cameras.....	21
2.4.5	COM 1 – Serial data transmission and GPS connection.....	22
2.4.6	COM 2 Interface – External modem connection.....	22
2.4.7	COM 3 and COM 4–Interface (IBIS and RS485).....	22
2.4.8	The audio interface.....	23
2.4.9	GPIO-interface – detector inputs and switch relay outputs.....	23
2.4.10	GPIO-Interface.....	24
2.4.11	“Ext. Devices“ Interface – IBIS, CAN and RS485.....	25
<b>3</b>	<b>Device Configuration - The main program CMS and its menu .....</b>	<b>26</b>
3.1	SystemManagement –module for device configuration.....	27
3.1.1	The device configuration.....	29
3.1.1.1	System :: Basic settings.....	31
3.1.1.2	System :: Time.....	34
3.1.1.3	System :: Passwords.....	35
3.1.1.4	System :: Version.....	36
3.1.1.5	Devices :: Cameras.....	36
3.1.1.6	Devices :: IP-Cameras.....	39
3.1.1.7	Devices :: Detectors.....	41
3.1.1.8	Devices :: Relays.....	42
3.1.1.9	Devices :: Audio.....	42
3.1.1.10	Connectors :: GPS.....	43
3.1.1.11	Connectors :: Network.....	44
3.1.1.12	Video output :: MultiView.....	45
3.1.1.13	Video output :: Transfer order.....	45
3.1.1.14	Activations.....	46
3.1.1.15	System events.....	48
3.2	The web interface of the system.....	51

---

<b>4</b>	<b>Relevant comments on the daily operation .....</b>	<b>52</b>
4.1	<b>Power supply and shutdown of the systems .....</b>	52
4.2	<b>Hold-back time of the permanent recordings versus data privacy .....</b>	52
4.3	<b>Shutdown behaviour of the system .....</b>	53
4.3.1	Shutdown behaviour during permanent and alarm recordings.....	53
4.3.2	Shutdown behaviour during data research.....	54
4.3.3	Influencing of the recording during data research .....	54
4.4	Overheat protection: temperature shutdown level of the system.....	55
4.5	Default configuration for factory reset .....	55
<b>5</b>	<b>Update &amp; Reset, maintenance, problem analysis and technical support.....</b>	<b>56</b>
5.1	Update of the device via the update tool.....	56
5.2	Update and Reset of the device via the web interface .....	56
5.3	Maintenance, cleaning and care of the system.....	57
5.4	Problem analysis and resolution .....	58
5.5	Technical support by the manufacturer.....	59
<b>6</b>	<b>Technical data of the MR3140 .....</b>	<b>60</b>
<b>7</b>	<b>Technical drawing .....</b>	<b>62</b>
<b>8</b>	<b>Abbreviations .....</b>	<b>63</b>

## 1 General information about DResearch video systems

### Congratulations on the acquisition of your MR3140!

Dear customer, thank you for deciding to purchase an MR3140 mobile hybrid recorder, we are most grateful for your custom. You have made an excellent choice in acquiring this device, a top quality product from DResearch. The MR3140 is a compact digital unit for recording video sequences from analogue and digital cameras as well as other associated data (IBIS and GPS). With industrial styling and a robust nature, the device is intended for mobile and static use under the severest conditions. Because of the particular application requirements of mobile CCTV monitoring, the MR3140 is designed to be a compact, efficient system with a long service life.

Owing to its tolerance of temperature variations and its resistance to vibration and shocks, corrosion, dust and moisture, the unit is particularly well equipped for flexible use in vehicles. The system digitizes and records up to 4 analogue video streams. Alternatively up to 8 digital video streams from IP cameras can be recorded from a local network. The MR3140 also has many interfaces for configuration, expansion, maintenance and integration in all-in-one systems. As many as 12 IP cameras can be set up in the network for display on a control room monitor.

Please take some time to read the user manual carefully so that you are familiar with the complete functional scope of the system and its application requirements. The documentation for the device is provided on the software CD supplied with the device.

### We wish you every success in working with the MR3140 mobile hybrid recorder!

DResearch devices at a glance	MR3060*	MR3140	MR3180	TO1200*	TO3100
Analogue recording	yes	yes	yes	-	yes
Digital recording	-	yes	yes	-	-
Video-IN analogue (max.)	6	4	8	4	8
Video-IN digital (max.)	-	8	8	-	-
Video-OUT	1	2	2	-	1
Transmission via SMS, Video (GSM, GPRS, EDGE) if an alarm is triggered	yes ***	yes ***	yes ***	yes **	yes **
GPS data recording	yes	yes	yes	yes	yes **
IBIS data recording	yes	yes	yes	-	yes **
Max. capacity HD in GB	500	250	250	-	160
Motion detection	yes	yes	yes	-	-
Sabotage detection	yes	yes	yes	-	-
Encryption/digital signature	yes	yes	yes	yes	yes
Digital inputs	6	6	8	6	8
Digital outputs/switch relays	4	4	2	4	6
RS232/485	yes	yes	yes	yes	yes
Video management software incl.	yes	yes	yes	yes	yes

\* The device TO1200 is from 2010 no longer available, the device MR3060 is available from 2010.

\*\* optional, depends on type of device

\*\*\* only for SMS transmission via external device

## 1.1 System overview and new functions in this version

### System overview

- Recording of video, audio, IBIS, GPS
- Hybrid mode: recording of up to 8 analogue and digital camera signals
- Formats - analogue: H264, CIF + 2CIF; digital: MJPEG, up to 1 MPx
- Hard disks: HDD / SSD (S-ATA) with capacity between 80 and 250 GB
- Recording into separated archives (alarm, pre-alarm, ring)
- Automatic deleting of archives, configurable hold-back time and maximum recording time
- Operating modes: pause, continuous recording, sleep
- Selftest of the unit and automatic securing of the data integrity
- Digital inputs for switches / buttons and alarm detectors
- Digital relay outputs to switch external devices
- Robust and fanless design, maintenance free, vandal safe
- Vehicle fit and certified in accordance to e1 and EN50155
- Extensive configuration options
- Ethernet interfaces, serial interface RS232, 485
- Sending SMS in the case of an alarm and for defined system events
- Data security: multi-level access protection, digital signing of the recorded data
- Numerous detectors for system disorders, motion and sabotage detection for analogue cameras
- Logically combinable system detectors and allocation of defined actions
- And much more...

**A detailed overview of the possibilities of the system is given in this document and further information materials, like system description or application concepts from DRResearch – request them or visit us on our website: [www.DRResearch.de](http://www.DRResearch.de)**

### New features in this firmware – version 6.1

- Suspension of the overheating protection: The upper temperature shutdown level can be increased – during the update – with the update tool from +55°C to +70°C. Please note the instruction of the update tool and the corresponding annotations in this document.
- Definable default configuration: During the update with the update tool you can specify if the factory settings of the manufacturer or the current configuration of the system shall be defined as default configuration. This default configuration will be loaded by a factory reset. Please note the instruction of the update tool and the corresponding annotations in this document.

## 1.2 Scope of delivery

- Digital hybrid recorder
- Removable hard disk (capacity between 80 – 250 GB)
- Software for configuration and analysis (Central Monitoring Software - CMS)
- Licences for the CMS
- Product CD with software and documentation

## 1.3 Accessories & additional devices

The devices can be expanded with various accessories. For a detailed list of all the accessories offered by DRResearch, please refer to the current product catalogue. For other information and ordering of accessories please contact your system integrator or our team direct.

### Assortment of additional devices for the system:

- Power supply unit 24V/2,5A
- Power – plug (ready-made 75cm cable with pin sleeves)
- Miscellaneous mounting material
- Service cable (crosslink and patch cables, serial service cable)
- Plug set **GPIO**, plug set **Ext. Device**
- Power-over-Ethernet switch (PoE) for supplying power to IP cameras
- DC/DC transformer (various input voltages, Out: 12-24V)
- Hard disks HDD/SSD: 80 - 250 GB
- Video- and network cables (CAT 5; 6 ) in various lengths
- GPIO tester

### Assortment of additional devices to extend the system:

- WLAN modules
- GPS receiver, GSM antenna in various versions
- UMTS/GPRS/HSDPA/HSUPA modems for data transfer
- Coupling systems for bridging vehicle clutches
- Various analogue and IP network cameras
- Coloured and b&w surveillance monitors for fitting into vehicles (trucks, buses, trams, trains)

A complete installation in a rail carriage when expanded with accessories could look like this:\*

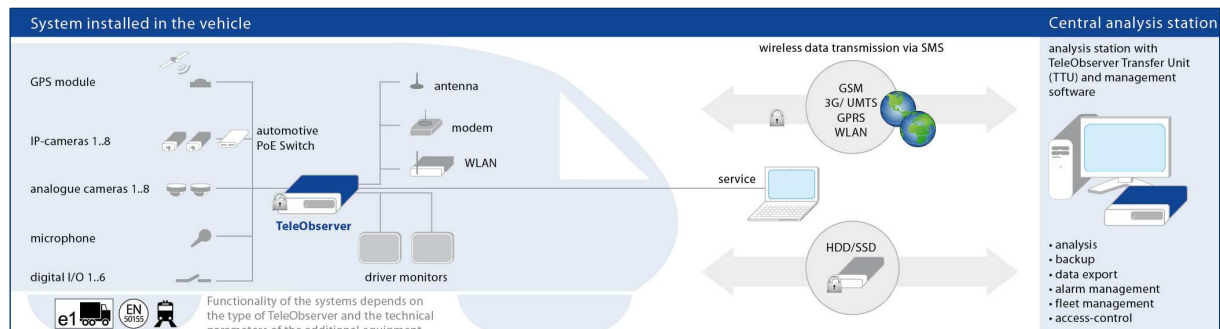

\* This is an illustrative example of the MR3180 – the MR3140 works with a maximum of four analogue cameras.

## 1.4 Safety advice

Incorrect handling can, at its worst, lead to personal injury or destruction of the device, and/or the termination of the guarantee. Therefore please be sure to note and follow the advice below before operating the device.

- **Never try to insert objects into any device openings since this could cause short-circuits or deliver electric shocks because of the voltage inside the unit.**
- **Only use original parts or products recommended by the manufacturer in the operation of the equipment. If you have a problem please consult your system integrator.**
- **Avoid installing equipment where it could be exposed to excessive smoke, dust, vibration, chemicals, moisture, heat, direct sunlight or electromagnetic fields. Such exposure can have a detrimental effect on the operation of the device and – in the worst case – can cause damage to the device.**
- **Never operate the device in locations where there is a danger that water might penetrate the device.**
- **When connecting up the device with the peripherals ensure that the cable is not under tension. Ensure all cables are installed properly.**
- **Only remove the hard disk from the device when all the LEDs on the front panel are off. To remind you this warning is printed on the front of the removable hard disk.**

**Remove only, when all LEDs are off!**



This is an (EMC, EN 55022) Class B system and can be used in all environments.

## 1.5 Warranty

The warranty terms for materials and manufacturing faults are, unless otherwise agreed by special negotiation, set out by DResearch Fahrzeugelektronik GmbH in its General Terms and Conditions. The General Terms and Conditions are to be found in the documents supplied. No further, expressed or tacit guarantees are accepted. The manufacturer is not responsible for claims arising from the improper handling or faulty installation by third parties.

The warranty is terminated if repairs or interventions are made by people who have not been authorised by the manufacturer. Claims arising from the inappropriate use of the equipment, incorrect maintenance or the use of accessories not recommended by the manufacturer are not covered under the terms of the warranty.



**Opening the device inevitably leads to the cancellation of all existing guarantee cover, guaranteed rights and agreed warranties.**

The supplied software and installation pack presuppose a conflict-free operating system. Solving problems relating to this require detailed knowledge of the systems used or their complete reinstallation. The manufacturer makes no guarantees that programs or systems operated by the user will deliver the desired benefits.

If a product is returned under the terms of the warranty this is always to be agreed in advance with the supplier, otherwise the return will not be processed. If returning an item, you will be given a returns number which is to be used throughout the procedure. The manufacturer takes no responsibility for damage or insurance during transit. Cash on delivery and 'carriage forward' shipments are not accepted.

## 1.6 Certifications, standards and conformities

The device is made to current safety and reliability standards (state: 09/2008) for use in a variety of environments. It was designed specially for use in trucks and locomotives and meets current requirements of various European standards.

### **Certifications, standards and conformities:**

- **CE compliant to EN 55022 class B**
- **RoHS conformity**
- **Conformity to European rail standard EN 50155**
- **e1 certification from the German Federal Bureau of Motor Vehicles and Drivers (KBA)**
- **Conformity to European EMC guidelines**
- **Vibration IEC 61373 (9) and shock IEC 61373 (10.5)**
- **Heat & fire resistance DIN 53438-2, DIN 5510-2**
- **EN 55024, EN 60950, EN 61000, EN 50121**

## 1.7 Scope of use

<b>Public transport sectors</b>
Trams, suburban railways, underground railways, buses, local and long distance trains and other vehicles
<b>Distribution, logistics and transport sectors</b>
Secure cash transport, transportation of hazardous loads, trailers and storage areas, high-bay warehousing and distribution centres, etc.
<b>Housing and construction industry</b>
Local properties, lifts and entrance halls as well as building sites.
<b>Industry and commerce</b>
Builders yards, industrial sites, waterworks and water treatment works, pumping stations, power stations, transformer substations, wind farms, geothermal power stations, retail branches, shopping centres, etc.
<b>Maritime - Offshore</b>
Locks, sea level measuring stations, oil drilling platforms, off-shore wind farms, etc.
<b>Private sector</b>
Holiday cottages, residential property, bungalows, boats, yachts, other vessels. Caravans, camper vans, etc.

## 1.8 General installation information

### Power supply

- The device must be plugged into a buffered power supply (UPS or unswitched supply/permanent positive).
- Do **NOT** use the on board train power supply switch to turn the system on. Use the ignition.
- Ensure that the device is wired up exactly as described in the manual.



Ensure there is a **constant** power supply of 12-24 VDC. Temporary power outages will be tolerated by the device but they are always to be avoided and can lead to system failures and permanent damage to the equipment (e.g. from lack of proper vehicle battery maintenance).

The UPS must be a device which has been recommended by the manufacturer and has valid certification for the application type.

Any damage resulting from disregarding this advice will not be covered by any guarantee or warranty.

### Cable length between device and cameras

Long connection paths between device and cameras have detrimental effects on the quality of the video signals. Select camera positions so that as much as possible of the area to be monitored can be covered with minimum cable lengths. Your system integrator will help you with the design of the system.

## **Ventilation and cooling**

Avoid installations where heat can build up. The equipment is designed to function without the need for a fault-prone fan, but adequate air circulation needs to be provided round the cooling fins.



**The system is equipped with an automatic overheating protection. In this case the system will be shut down automatically and controlled if the internal temperature is 55°C. Please note that the internal temperature may be up to 15°C above the ambient temperature.**

Select the installation place so that heat accumulations can be avoided and the system is sufficiently cooled by air circulation. Further information about overheating protection you will find at the end of this document.

## **Mounting**

The device has 2 guide rails on the top and bottom which take mounting screws. If at all possible, mount the device on a mounting plate which can also take the necessary additional components such as a transformer and connection block.



**The device must not be mounted with the hard disk drive aperture facing down! When fitting ensure that it is possible to change the removable hard disks easily!**

### **1.9 Temperature range**

Storage temp.:	maximum + 70°C
Operating temp.:	0°C to + 55°C (normal HDD) 0°C to + 70°C (HT- HDD, SSD)
Humidity:	10 ... 90 % (not condensed)



**When using conventional data storage devices (HDD) the unit will automatically shut down when it reaches its temperature limit of + 55°C (for normal HDD) in order to protect the hard disk.**

When the temperature reduces to below this limit, the device will automatically switch back on. This temperature-dependent switching event is stored in a log file.

## 1.10 System components and device features

The complete system consists of three different modules which communicate with each other via a proprietary software data protocol which is the same irrespective of the operating system.

### The device MR3140

- Data recording and storage of video streams with metadata according to the predetermined configuration
- Storage on a removable hard disk
- Connection of up to two control monitors
- Function and configuration: see following chapters
- Default IP address of the device when shipped: 192.168.0.1

### Service computer and analysis station

Usually the review station is used for analysing the recorded data. A service laptop is often employed for installation, configuration and system maintenance. A standard commercial computer can be used.

Currently DRResearch offers two software packages:

#### **Central Management Software (CMS)**

with the modules **Vision**, **ImageFinder** and **SystemManagement** for

- Visualisation of recorded data (video, add. data)
- Searching recorded data according to freely configurable parameters (e.g. time, events etc.)
- Display of live video sequences (incl. additional data)
- Device configuration
- Operating systems (OS) supported: Windows XP Prof. and Vista

#### **ImageFinderNX**

**The analysis software ImageFinder NX is the successor of the CMS module ImageFinder** and provides a convenient search and analysis of the recorded data. The software is usable in conjunction with the USB-TTU. A direct search at the device is possible from version 1.5. The usage requires Windows operating systems Windows XP Prof. (SP 2) or Vista.

**The previous CMS module ImageFinder will be developed only until the end of 2009 and then discontinued!**

### The TeleObserver Transfer Unit (USB-TTU)

This separate device (USB-TTU) has the following uses:

- Taking the removable hard disk for the evaluation/analysis of data.
  - Formatting the hard disk.
  - Activating removable hard disks and decoding data (when using **DR.Secure** encryption).
  - Displaying synchronous video images.
  - Analysing of the recorded data (video, audio, add. Data, such as IBIS and GPS).
  - Creating backups.
  - Export of video data, printing of pictures etc.
- (For a detailed description of all the features have a look in the manual of the USB-TTU.)

Detailed information you will find in this manual and the data sheet.

#### System specification – an overview

- Hybrid recorder for recording video, audio and metadata, designed for buses, trains, trams and other vehicles, certified to e1 and EN 50155
- 4 x video-in analogue (BNC), 8 x video-in to record from IP network cameras (AXIS, Mobotix and others up to 1 Megapixel, 1280 x 1024 Pixel)
- 2 channel audio recording (e.g. for the documentation of the driver communication)
- Removable hard disk HDD / SSD: up to 250 GB HDD
- 2 x video-OUT for analogue and up to 12 IP network cameras, split screen display and onward signal switching
- Recording of metadata such as IBIS (VDV 300), GPS
- Interfaces: RS232, RS485, Ethernet, IBIS
- 6 digital alarm inputs (for alarm triggering devices) and 4 digital outputs (for switch relays)
- Integrated power supply for 4 analogue cameras
- Compact, robust industrial design for use in the most difficult conditions with protection against vibration
- Safe from vandalism through stable cast aluminium housing (continuous casting)
- Maintenance-free through fan-free operation

#### Software and data management

- Live video pictures, search and playback function and fast video download via an Ethernet-interface
- Configuration and management software with ergonomic graphical user interface
- Expanded event and information management, including IBIS / GPS metadata
- Support for alarm and fleet management
- Data encryption, watermark, sabotage recognition, role-based access management, motion detection
- Flash based real-time operating system and hardware control system
- MJPEG and H.264+ (MPEG-4 AVC) picture compression with recording rates up to 200 frames per second
- SMS support for alarm events as well as for maintenance/service-support (GSM modem required)

Feature	Description
Configurable video recording	<ul style="list-style-type: none"> <li>▪ Recording of video sequences from up to 8 cameras (hybrid operation of analogue and IP cameras) in automatic generated archives (one ring, alarm and pre-alarm archive per camera).</li> <li>▪ Maximum of 25 pictures/s for analogue cameras to the 4 video inputs</li> <li>▪ Recording of up to 8 IP cameras with a maximum of 25 pictures/s per camera</li> <li>▪ Definable setting for maximum age for the video footage.</li> </ul>
Configurable picture resolution (picture format)	<p><b>The picture format has to be determined before recording begins!</b></p> <ul style="list-style-type: none"> <li>▪ Recording formats from analogue cameras: <ul style="list-style-type: none"> <li>▪ <b>CIF</b> (352 x 288 = 101 376 Pixels)</li> <li>▪ <b>Half frame/2CIF</b> (704 x 288 = 202 752 Pixels)</li> </ul> </li> <li>▪ Recording formats from IP cameras: The IP camera picture format has to be determined in the camera set up – not via CMS!</li> </ul>
Configurable picture quality	<ul style="list-style-type: none"> <li>▪ For each analogue camera there are 5 different settings for the picture quality of the recorded video footage.</li> <li>▪ The picture quality from the IP cameras is determined by the camera configuration settings.</li> </ul>
Configurable alarm recording	<ul style="list-style-type: none"> <li>▪ Pre- and post-alarm recording times are configurable.</li> <li>▪ Events can be used to start alarm recording.</li> <li>▪ Data recorded with this feature are marked as such. The alarm footage is not automatically overwritten.</li> <li>▪ The maximum age of the alarm sequences can be determined.</li> </ul>
Activated alarm recording display	<ul style="list-style-type: none"> <li>▪ If alarm recording is activated, this is indicated by the yellow HD LED and it is displayed on the control monitor.</li> </ul>
Configurable metadata recording	<ul style="list-style-type: none"> <li>▪ Besides video footage, additional data such as date/time, camera name, IBIS and GPS data can be recorded.</li> </ul>
Calling up status information	<ul style="list-style-type: none"> <li>▪ Information about the current status of the device is indicated via the devices LEDs and displayed on a control monitor (OSD).</li> </ul>
Display of the event log	<ul style="list-style-type: none"> <li>▪ Information about the device is recorded in the event log. The log can be viewed in the searching software.</li> </ul>
System events	<ul style="list-style-type: none"> <li>▪ Indicate the various device and archive conditions. They can be viewed on a control monitor (OSD).</li> </ul>
Motion detection	<ul style="list-style-type: none"> <li>▪ Trigger-level-controlled motion detection</li> <li>▪ Motion detection can be limited by masking off particular areas of the picture.</li> <li>▪ Configurable actions in response to motion detection e.g. alarm recording and/or switching relays.</li> </ul>
Camera sabotage	<ul style="list-style-type: none"> <li>▪ Trigger-level-controlled camera sabotage detection (only for analogue cameras)</li> <li>▪ Configurable actions in response to camera sabotage, e.g. relay switching, sending SMS.</li> </ul>

## 2 The recording device MR3140 in detail

### 2.1 Device description

The MR3140 is one part of the complete recording system and works without a fan. The housing is made from non-rusting, maintenance-free material. The data transmission and recording processes in the device are encrypted to prevent unauthorised access to the data. The file and security operating systems used prevent loss of important files if there is a power outage and therefore maintain continuity.

The device forms the switching centre and link between all other system components. It provides the interfaces for the connection of cameras, peripherals such as WLAN modem, GSM modem, PoE switch, driver monitors, relays and switches as well as other components.

#### Front view of the MR3140

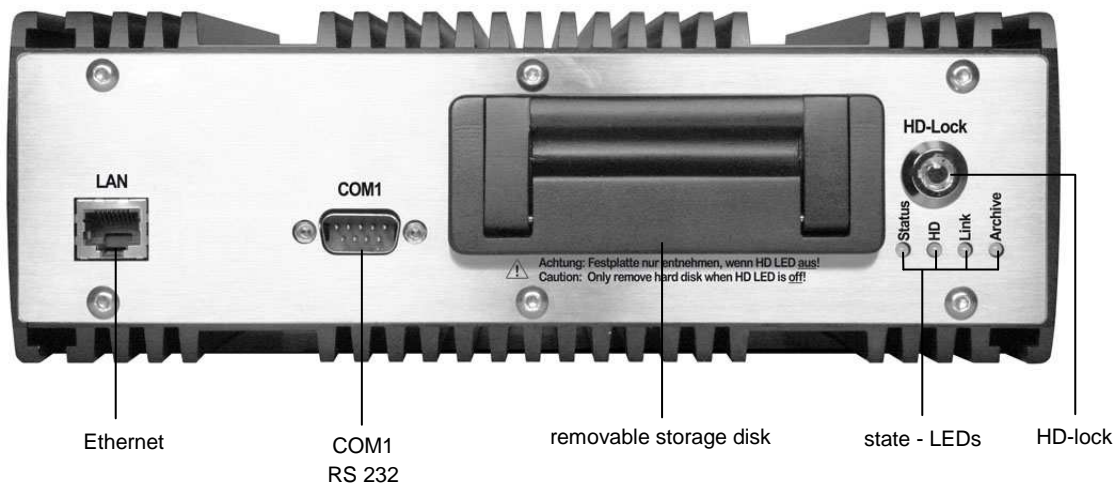

#### Rear view of the MR3140

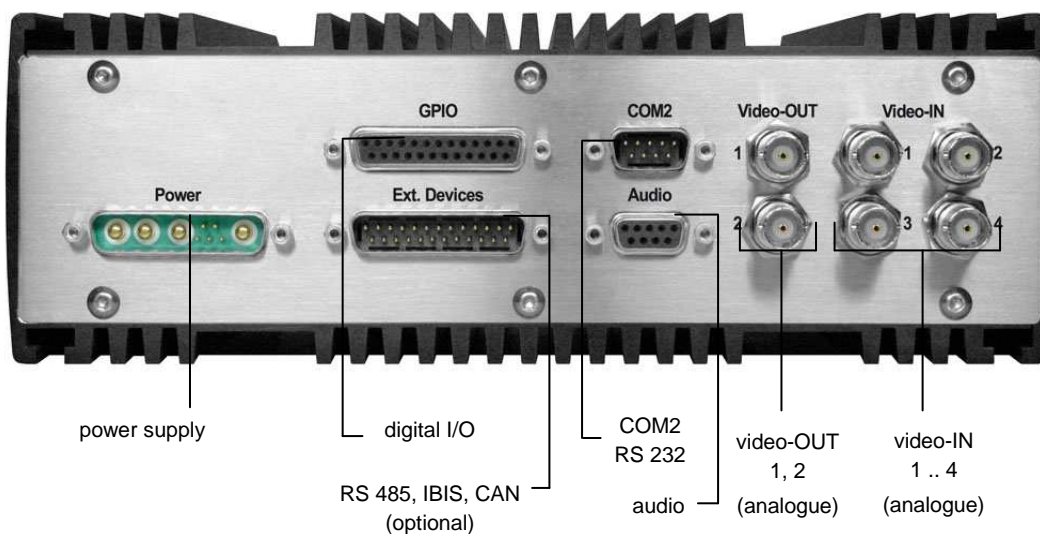

## 2.2 Changing and inserting the removable disk



### the MR recorder series' removable disk

Please ask your system integrator or the manufacturer about the sizes and models currently available.



In MR3140 devices use only the hard disks provided and pre-formated by DRResearch. Only hard disks with the same capacity should be used within each fleet. For more information and for ordering hard disks please contact the sales team (E-Mail: [sales@dresearch.de](mailto:sales@dresearch.de)).

Use only original hard disks from the manufacturer!  
Otherwise all existing warranties and guarantees are invalidated.



Only remove the hard disk when all the LEDs on the front of the device are off! Removing the hard disk before the LEDs go out results in damage to the device. All warranties and guarantees are thereby invalidated!

To prevent any manipulation of the data, the hard disk is adopted by the device. This process happens when the device starts up with the hard disk for the first time. Only after this can recording start. To prepare the device for recording for the first time proceed as follows:

- Switch the device off and wait until all the LEDs have gone out (by unlocking the HD lock) – this takes several seconds.
- Without using physical force carefully insert a formatted (!) removable hard disk (label upwards) in the carrier guides.
- Lock the HD lock again.
- The system will start again (so long as the power is on).
- The hard disk capacity will be automatically allocated to the camera archives by the software. No further intervention is necessary.



If you anticipate exchanging hard disks between different devices (so-called interchange of hard disks) then the following details are important – please note the configuration of the basic settings!

The hard disk is a sensitive part of the system. To ensure constantly reliable functioning we recommend checking up the hard disks every 3 months.

After changing the hard disk the device needs 2 minutes to examine and adapt the disk. Turn off the device after initial boot with a new disk earliest after 2 minutes!

### 2.3 Significance of the status LEDs

On the front of the unit there are four coloured LEDs which indicate the current status of the device. At any time you can determine the current status of the device from the colour codes. We recommend that you print out the following table and keep it with your service documents.

LED	State	Description
<b>Status</b> (state of the device)	off	▪ device is switched off
	green	▪ device is ready for operation
	orange	▪ device is booting or shutting down
	red	▪ Error – contact the service department!
<b>HD</b> (recording)	off	▪ device is not recording
	green	▪ actively recording into the ring archive (normal)
	orange	▪ actively recording into the alarm archive (alarm event)
	orange flashing	▪ HD will be deleted and adopted by the device in 30 seconds
	red	▪ hard disk is not available or could not be recognised/adopted by the device ▪ <b>no recording on the hard disk</b> ▪ other errors
<b>Link</b> (LAN-connection)	off	▪ no connection between PC and device
	green	▪ active data transmission, connection between PC and device
	orange	▪ not busy
	red	▪ Error – no communication
<b>Archive</b> (archive fill level)	off	▪ archives cannot be recognised (fault)
	green	▪ 0% - 60% of the capacity full
	orange	▪ > 60% - 80% of the capacity full
	red	▪ > 80% - 100% of the capacity full

The codes listed here could be changed by the manufacturer. If in doubt contact your system integrator or the manufacturer.

## 2.4 Device interfaces

### 2.4.1 Analogue video inputs 1 ... 4 – connection of analogue CCTV cameras

Up to four standard commercial CCTV cameras can be connected via the BNC connections **IN 1** to **IN 4** (rear of device) provided they have BNC connectors and deliver an analogue CCIR standard (CVBS, PAL/NTSC) signal. The operating voltage for the cameras is provided by the MR3140 recorder itself (12V).

Before video footage can be recorded from a camera (analogue and IP), video recording for this camera has to be explicitly activated in the Central Monitoring Software (see configuration chapter).



**Note that you can only ensure a stable camera power supply of 12 V if the power supply to the recorder is always over 13V.**

### 2.4.2 LAN Interface – connection of IP network cameras or other devices

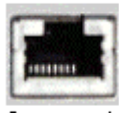
	Pin	Name	Description
 8 1	1	Tx+	Transceive Data+
	2	Tx-	Transceive Data-
	3	Rx+	Receive Data+
	4		Not used
	5		Not used
	6	Rx-	Receive Data-
	7		Not used
	8		Not used
<b>This interface supports a bandwidth of 100 Mbit</b>			

Pinout of the RJ45 network interface

Using the RJ45-interface (LAN, Ethernet) and a patch cable (CAT 5 or higher) you can connect the device with other external devices. This might be:

- A computer** - for configuration and/or control through the CMS
- External devices** - such as a WLAN-modem, a switch, a single IP-camera or several IP-cameras over a switch

#### Connection of IP-cameras

Up to 12 IP cameras can be connected via the LAN interface and an external switch (see system diagram on page 4). Video recording can be activated for up to 8 IP cameras, the remainder can be set up in parallel to provide video pictures on a monitor.



**Please note that the device does not support Power over Ethernet (PoE). Depending on the type of cameras used (e.g. AXIS 209 FD-R) their power supply has to come via a separate power supply unit or the PoE supply belonging to the external switch. Consult the relevant camera manual for power supply details.  
Only use DRResearch recommended accessories!**

### 2.4.3 Video Out 1 and 2 – connection of control monitors

Two control monitors for monitoring the cameras can be connected in parallel via the recorder's analogue video outputs. This enables the camera pictures to be viewed in two different locations.

The cameras to be displayed on the monitors can be configured in the **SystemManagement** software module. All 4 analogue and up to 12 IP cameras can be displayed using a video switcher and/or in multi-view (single, quad, nona etc.). The position of the individual camera signals/video pictures within the screen and the switching sequence can be individually configured.



**It is not necessary for the relevant camera to be activated for recording in order to display video pictures. Although only 8 IP cameras can be activated for recording, up to 12 IP cameras can be connected to the recorder via the external switch and all 12 video signals can be displayed.**

**Please note that displaying video makes additional demands on the device. Too many video signals can lead to reduced frame rates and hesitation in playback on the video OUT. Because of this only set those cameras for video OUT which are absolutely necessary. Usually it makes sense only to set up those cameras which cover sensitive areas (vehicle entry area or rear view camera).**

A suitable monitor is available directly from DRResearch. Please look at our current product catalogue or contact us.

#### 2.4.3.1 Sequential video output and multiviews

Live pictures from the linked cameras can be switched through in sequence to be shown on the control monitor – this is controlled via a digital input. Configuration is dealt with in full in chapter 3.

**2.4.3.2 Display of information and system events (OSD)**

Using OnScreenDisplay the recorder shows additional information in the form of symbols and texts when particular system events and alarms occur. The following information and system events are displayed:

Symbol	Significance	Description
□ □ □ □ □ □	Name of the warning device	<ul style="list-style-type: none"> <li>▪ Symbols for the six digital inputs <b>IN1</b> to <b>IN6</b>.</li> <li>▪ Displays the number of the active alarm or electromechanical lock at the bottom of the screen.</li> </ul>
⊗	-	<ul style="list-style-type: none"> <li>▪ Alarm in the last hour.</li> <li>▪ Automatically increases the duration if another alarm is activated or deactivated within this period.</li> </ul>
*	Alarm recording active	<ul style="list-style-type: none"> <li>▪ Alarm sequence recording.</li> </ul>
HD (!)	No disk found	<ul style="list-style-type: none"> <li>▪ No disk or disk faulty.</li> </ul>
HD (60%) HD (80%)	Alarm archives 60% full Alarm archives 80% full	<ul style="list-style-type: none"> <li>▪ At least 60% (or 80%) of the hard disk capacity has been written with alarm footage.</li> </ul>
HD (full)	Alarm archives full	<ul style="list-style-type: none"> <li>▪ No further alarm sequence recording possible.</li> <li>▪ Archiving and release of the alarm archive in <b>ImageFinder</b>.</li> </ul>
GPS	GPS fault	<ul style="list-style-type: none"> <li>▪ Device is not receiving GPS signal.</li> </ul>
IBIS	IBIS-Bus fault	<ul style="list-style-type: none"> <li>▪ Device is not receiving IBIS signal.</li> </ul>
RMC	RMC fault	<ul style="list-style-type: none"> <li>▪ Fault in the Rail Media Coupler.</li> </ul>
IP (1..8)	Camera number	<ul style="list-style-type: none"> <li>▪ IP camera video signal missing.</li> </ul>
A (1..4)	Camera number	<ul style="list-style-type: none"> <li>▪ Analogue camera video signal missing or camera has been sabotaged or covered.</li> </ul> <p>(A = camera group A = 1..4)</p>

Alarm system conditions and events indicators

### 2.4.4 Power supply for the device and cameras

The interface provides power for the device itself and makes supply voltage available for further external devices (12V DC; e.g. analogue cameras). The device is switched on and off via a connection through the vehicle’s ignition switch.

Interface	Pin	Name	Description
	A1	Camera_POWER(+12V)	+ camera power supply
	A2	POWER_IN (12V – 32V)	+ power supply
	A3	GND	- power supply
	A4	Camera_GND	- camera power supply
	1	-	
	2	-	
	3	Input1+	Ignition, high, galvanically separated (optocoupler)
	4	Input1-	Ignition, low, galvanically separated (optocoupler)
	5	-	

Pinout of the **Power** interface

**Ensure there is a constant power supply of 12-24 VDC on Pin A2. Temporary power outages (e.g. from lack of proper vehicle battery maintenance) will be tolerated by the device but they are always to be avoided and can lead to system failures and permanent damage to the equipment.**

The UPS must be a device which has been recommended by the manufacturer and has valid certification for the application type. Any damage resulting from disregarding this advice will not be covered by any guarantee or warranty.

#### Example showing connection of device and cameras

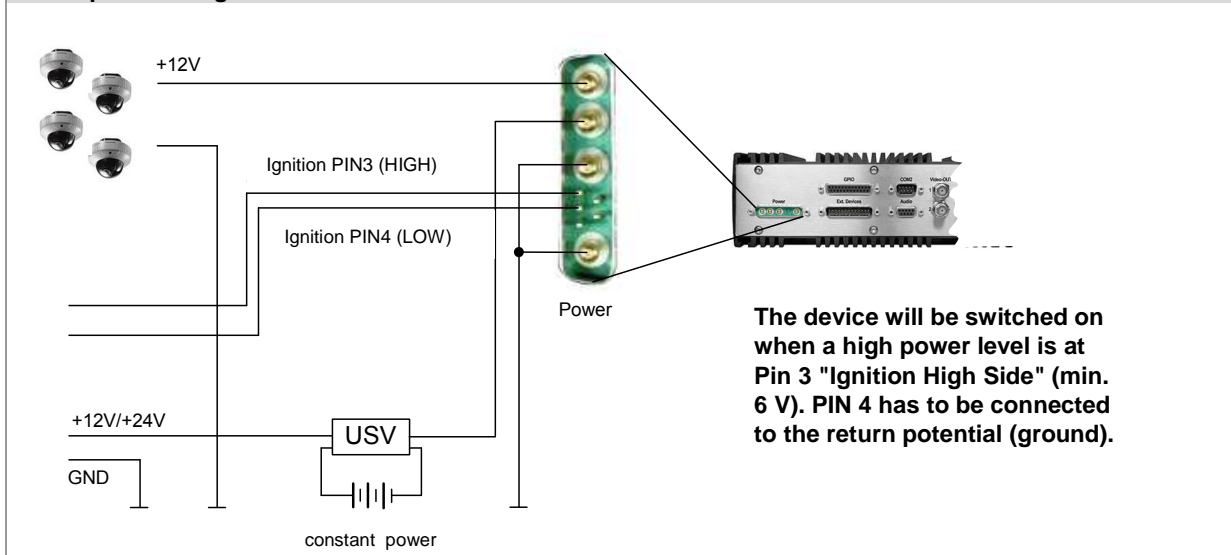

### 2.4.5 COM 1 – Serial data transmission and GPS connection

The serial COM1 port (RS232) on the front of the recorder is used (as a service interface) for maintenance of the device or for connecting external devices such as a GPS receiver or modem.

The interface (D-SUB 9, male) is configured as standard for RS232:

Interface	Pin	Name	Description
 1 5 6 9 (male)	1	CD	Carrier Detect
	2	RxD	Receive Data
	3	TxD	Transmit Data
	4	DTR	Data Terminal Ready
	5	GND	System Ground
	6	DSR	Data Set Ready
	7	RTS	Request to Send
	8	CTS	Clear to Send
	9	RI	Ring Indicator

Pinout of interface COM 1

#### **GPS receiver connection**

Note that the only navigation systems and GPS receivers supported are those recommended by DRResearch. The GPS receiver can be connected directly to the COM1 port. The port parameters can be configured in **SystemManagement** → **GPS**. (See Chapter 3, Configuration.)

#### **Use as service interface**

The service interface allows analysis of the device using a terminal. This should only be carried out by authorised experts. This requires the use of a fully wired serial service cable from DRResearch.

### 2.4.6 COM 2 Interface – External modem connection

An external modem for sending SMS messages can be connected via the COM2 (RS232) port. The only modems which are supported are these ones available as accessory. A connected modem is automatically recognised by the recorder. A SMS-capable software receiver must be installed on your PC. This is not included in the shipment!



**When operating a GSM modem for the first time the access to the relevant providers has to be configured (PIN, AT commands etc.) before inserting the SIM card and connecting the modem to the MR3140.**

**Incorrect operation can lead to the SIM card being blocked! DRResearch takes no responsibility for the costs associated with a blocked SIM card if the above instructions are ignored and the equipment is operated improperly!**

### 2.4.7 COM 3 and COM 4–Interface (IBIS and RS485)

Ports COM 3 and COM 4 (RS485) are used for connecting the IBIS-Bus (COM 3) and any external RS485 devices (e.g. a GPS-receiver). Both ports lead out via the pins on the unit's **Ext. Device** external interface.

### 2.4.8 The audio interface

Use the audio adapter cable which is provided in the accessories to connect external audio devices to the recorder. The interface (D-SUB 9, female) is wired as follows:

Interface	Pin	Name	Description
 9 6 (female)	1	Audio PWR2	Microphone phantom voltage 2
	2	AudiIn2	Audio input 2
	3	GND	Audio GND
	4	AudiIn1	Audio input 1
	5	Audio PWR1	Microphone phantom voltage 1
	6	GND	Audio GND
	7	GND	Audio GND
	8	GND	Audio GND
	9	GND	Audio GND

Audio interface pin layout

### 2.4.9 GPIO-interface – detector inputs and switch relay outputs

#### Sensor input 1 ... 6

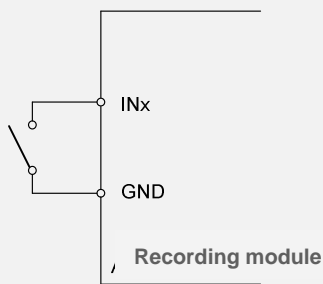

Each of the 6 available inputs is constructed as shown in the adjacent circuit.

Sensor systems can be connected as desired depending on requirements. This allows the MR3140 to be fully integrated within existing systems.

#### Relay output 1...4

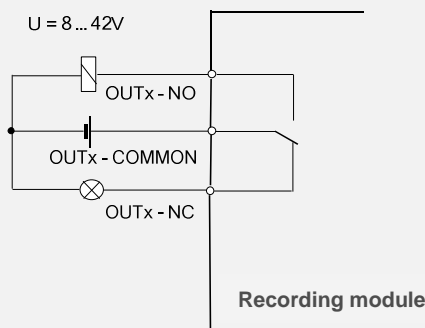

Each of the 4 relay outputs is constructed as shown (left).

Here too the connection options enable the recorder to offer full flexibility for the connection of devices and systems.

It is possible to connect indicators, diodes and bulbs or to control other whole systems directly.

### 2.4.10 GPIO-Interface

The GPIO interface (HD-SUB 25, female) provides for the connection of alarm detectors. For this use the **GPIO connector set** which can be obtained as an accessory from your system integrator or DResearch. Up to 6 sensors (digital inputs, optocoupler inputs) and 4 digital switch outputs (relays) can be connected.

Pin	Name	Description	Pin	Name	Description
					
1	OUT2-COMMON	Relay output 2 – common contact	14	OUT4-COMMON	Relay output 4 - common contact
2	OUT2-NC	Relay output 2 – unprotected contact	15	OUT4-NC	Relay output 4 - unprotected contact
3	OUT2-NO	Relay output 2 – make contact	16	OUT4-NO	Relay output 4 - make contact
4	OUT1-COMMON	Relay output 1 - common contact	17	OUT3-COMMON	Relay output 3 - common contact
5	OUT1-NC	Relay output 1 - unprotected contact	18	OUT3-NC	Relay output 3 - unprotected contact
6	OUT1-NO	Relay output 1 - make contact	19	OUT3-NO	Relay output 3 - make contact
7	GND	Reference potential for digital inputs	20	GND	Reference potential for digital inputs
8	IN6	Digital input 6	21	GND	Reference potential for digital inputs
9	IN5	Digital input 5	22	GND	Reference potential for digital inputs
10	IN4	Digital input 4	23	GND	Reference potential for digital inputs
11	IN3	Digital input 3	24	GND	Reference potential for digital inputs
12	IN2	Digital input 2	25	GND	Reference potential for digital inputs
13	IN1	Digital input 1			

Pinout of interface general purpose input/output (GPIO)

2.4.11 “Ext. Devices“ Interface – IBIS, CAN and RS485

**External Devices interface - Pinout**



The (HD-SUB-25, male) socket marked **Ext. Devices** on the recorder is an RS485 interface. This is shown as **COM4\*** in the setup configuration. This connection is used for the connection and integration of an IBIS system or a rail media coupler. The interface is also suitable for connecting an external GPS receiver. A connection for a CAN bus \*\* is offered as an additional option.

To use this interface the **plugset ext. device** is required. This can be obtained from your system integrator or from the manufacturer.

Pin	Name	Description	Pin	Name	Description
1	GND	Ground	14	WBSD	IBIS Call -Bus Signal
2	CAN_GND**	CAN Ground**	15	WBMS	IBIS-GND-Call-Bus
3	CAN_L**	CAN_L Bus Signal**	16	WBED	IBIS-Response-Bus Signal
4	CAN_H**	CAN_H Bus Signal**	17	WBME	IBIS-GND- Response -Bus
5	reserved		18	GND	Ground
6	GND	Ground	19	not used	
7	GND	Ground	20	reserved	
8	reserved		21	not used	
9	reserved		22	reserved	
10	reserved		23	not used	
11	GND	Ground	24	GND	Ground
12	RS485A	RS485 Signal A	25	GND	Ground
13	RS485B	RS485 Signal B			

\* **IBIS = COM3, RS485 = COM4**

\*\* The hardware is prepared to support a CAN-Bus and can be offered. Contact DRResearch about this.

Pinout of interface Ext. Devices

### 3 Device Configuration - The main program CMS and its menu



To set up a connection to the device, an outstation with the name of your choice (e.g. MR3140\_001) and the IP address of the MR3140 (Default: 192.168.0.1) has to be set up in the CMS module SystemManagement → Outstaion.



The CMS consists of the modules Vision, ImageFinder and SystemManagement. Only the system management module is relevant for the configuration of the recorder. There is a detailed description of the CMS software in the software manual.

#### Vision - Display of live pictures

With the MR3140 this module can be used for the installation of a whole system for adjusting and function checking the cameras. Proceed as follows:

- Create a connection between PC and device (Ethernet).
- Start the CMS and afterwards **Vision**.
- Connection to the device → **Connect**.
- After successfully establishing the connection you will see the camera pictures.

#### ImageFinder – search of recorded data

Enables the searching of recorded video data. The various types of archives are shown colour coded: ring archive (green), alarm archive (red) and pre-alarm archive (yellow). Archives are automatically established for each camera which is activated for recording in the system management module. Proceed as follows:

- Creating a connection between PC and device (Ethernet).
- Start the CMS and then **ImageFinder**.
- Connection to the device → **Connect**.
- Once the connection is established the recorder's individual archives will be shown.

#### SystemManagement – module for device configuration





**Configuration should only be conducted by the manufacturer's authorised specialist. The manufacturer accepts no liability or responsibility if damage results from improper treatment or incorrect settings.**

- Create a connection between the PC and the recorder (Ethernet).
- Start the CMS and then **SystemManagement**.
- Load the device configuration → **Received**.
- After the connection is made the device configuration will be loaded.

The following section will deal in detail with the menu of the SystemManagement module and the configuration of the device.

### 3.1 SystemManagement –module for device configuration

Function bar	
	
<p>The individual functions are activated depending on the function call-up of the selection window.</p>	
Menu and description	
Save	<ul style="list-style-type: none"> <li>▪ Saves the setting local on the PC, not on the device.</li> </ul>
Undo	<ul style="list-style-type: none"> <li>▪ Currently selected changes are discarded.</li> </ul>
Initializing	<ul style="list-style-type: none"> <li>▪ System is re-initialised.</li> <li>▪ Communication unit is re-started.</li> </ul>
Connect	<ul style="list-style-type: none"> <li>▪ Opens the <b>Connection</b> dialogue box in which the device will be selected of which the configuration is to be loaded. After selecting and setting up the connection to the device the configuration is loaded.</li> </ul>
Reject	<ul style="list-style-type: none"> <li>▪ Button is active when the recorder configuration is loaded.</li> <li>▪ Any configuration changes which have just been made are discarded and the device configuration menu is closed.</li> </ul>
Transmitting	<ul style="list-style-type: none"> <li>▪ Current configuration changes are transmitted to the device, the configuration menu is closed and the device starts with new settings.</li> </ul>
New	<ul style="list-style-type: none"> <li>▪ Activates the entry fields.</li> </ul>
Delete	<ul style="list-style-type: none"> <li>▪ Deletes a selected element</li> <li>▪ Is activated with the <b>New</b> button.</li> </ul>
Info...	<ul style="list-style-type: none"> <li>▪ Activates a window with the current version number.</li> </ul>

The main menu	
 <p>The functions <b>File</b>, <b>Connection</b>, <b>Edit</b>, <b>View</b> and Info (?) are available in the <b>SystemManagement</b> main menu.</p>	
File	
Save	<ul style="list-style-type: none"> <li>Saves all current changes.</li> <li>Only effective after system is initialised (menu option Initialising).</li> </ul>
Cancel	<ul style="list-style-type: none"> <li>Cancels the current procedure.</li> </ul>
Initialising	<ul style="list-style-type: none"> <li>Re-initialises the system.</li> </ul>
Save as	<ul style="list-style-type: none"> <li>Saves the configuration.</li> <li>First give the outstation a name.</li> </ul>
Open	<ul style="list-style-type: none"> <li>Opens a saved configuration (choose from directory).</li> <li>For security reasons saved configurations from other MR3140 devices cannot be opened and transmitted.</li> </ul>
Close	<ul style="list-style-type: none"> <li>Closes SystemManagement.</li> </ul>
Connection	
Receive settings	<ul style="list-style-type: none"> <li>Sets up a connection to the MR3140 and receives the settings from an outstation.</li> <li>The dialog <b>Connection</b> will be opened.</li> </ul>
Reject settings	<ul style="list-style-type: none"> <li>Is active if the device's configuration menu is loaded.</li> <li>Current configuration amendments are discarded and the device configuration menu is closed.</li> </ul>
Send settings	<ul style="list-style-type: none"> <li>Sets up a connection to the MR3140 and sends the amended settings to the device. Then the device starts with the new settings.</li> </ul>
 <p><b>Before establishing a connection with the outstation (MR device) check whether this is also in operation. If the device is not available an appropriate error message will be shown. In this case the device is either switched off, the connection to the device is broken (cable) or the network settings are not correct.</b></p>	
Edit	
Undo	<ul style="list-style-type: none"> <li>Undoes the new changes made.</li> </ul>
New	<ul style="list-style-type: none"> <li>Activates the entry fields.</li> </ul>
Delete	<ul style="list-style-type: none"> <li>Deletes a selected element.</li> <li>Is activated with the <b>New</b> button.</li> </ul>
View	
Tooltips	<ul style="list-style-type: none"> <li>Switches on and off the brief help tips which appear when the mouse rests on individual dialog fields.</li> </ul>
?	
Info about	<ul style="list-style-type: none"> <li>Activates a window with the current version number and copyright details (equivalent of the <b>Info</b> button in the function bar).</li> </ul>

### 3.1.1 The device configuration

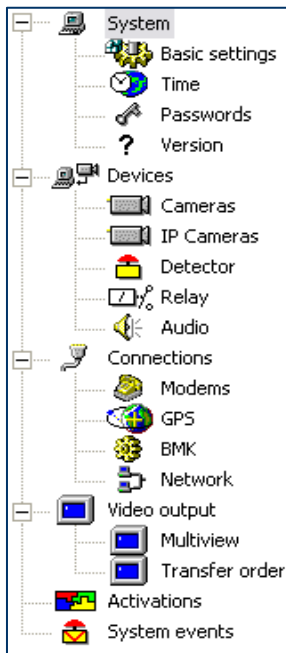

The device configuration is loaded via **SystemManagement → Receive**.

After selecting the particular device the configuration data is displayed in tree form.

By selecting the individual entries on the left, the relevant dialogue box opens (on the right).

The individual dialogue fields with the parameters and their significance are described in detail below.

System	
Basic settings	<ul style="list-style-type: none"> <li>▪ <b>General Settings</b> (system follow-up time, system language, video output properties) and <b>archive settings</b> (storage duration, pre and post alarm times).</li> <li>▪ IBIS and/or GPS data recording can be activated.</li> </ul>
Time	<ul style="list-style-type: none"> <li>▪ Select the time zone and the time synchronisation process.</li> </ul>
Passwords	<ul style="list-style-type: none"> <li>▪ Entry or change:                             <ul style="list-style-type: none"> <li>▪ the passwords for remote configuration and hard disk access</li> <li>▪ the access code for the MR3140.</li> </ul> </li> </ul>
Version	<ul style="list-style-type: none"> <li>▪ Displays the serial number and hard and software version for the MR3140 device.</li> </ul>
Devices	
Cameras	<ul style="list-style-type: none"> <li>▪ Can set <b>general camera settings</b> (video standard, picture rate) and <b>specific camera settings</b> (activation of video recording, motion detection and sabotage detection, quality, resolution, brightness, contrast, colour saturation).</li> </ul>
IP cameras	<ul style="list-style-type: none"> <li>▪ Configuration of camera name and IP address.</li> </ul>
Detector	<ul style="list-style-type: none"> <li>▪ Configuration of the digital inputs – selectable types: <b>opener</b>, <b>closer</b> or <b>block lock</b>.</li> <li>▪ If the block lock is activated neither external events will be analysed by the detectors nor actions triggered.</li> </ul>
Relay	<ul style="list-style-type: none"> <li>▪ All relays are shown.</li> </ul>
Audio	<ul style="list-style-type: none"> <li>▪ Settings for audio recording.</li> <li>▪ If this option is activated audio data will be recorded uncompressed.</li> </ul>

<b>Connections</b>	
Modems	<ul style="list-style-type: none"> <li>▪ Configuration of modem settings and interface parameters.</li> </ul>
GPS	<ul style="list-style-type: none"> <li>▪ Configuration of GPS properties and the interface parameters.</li> </ul>
RMC	<ul style="list-style-type: none"> <li>▪ Activation of the rail media coupler (if available).</li> </ul>
Network	<ul style="list-style-type: none"> <li>▪ Configuration of IP addresses from the device and the gateway.</li> </ul>
<b>Video output</b>	
Multi View	<ul style="list-style-type: none"> <li>▪ Configuration of multi-views for the video outputs (Video-OUT 1..2).</li> <li>▪ Definition of certain views for the output on an external monitor.</li> </ul>
Transfer order	<ul style="list-style-type: none"> <li>▪ Configuration of the switch through sequence for video output.</li> </ul>
<b>Activations</b>	
	<ul style="list-style-type: none"> <li>▪ Configuration of detectors and associated activations.</li> </ul>
<b>System events</b>	
	<ul style="list-style-type: none"> <li>▪ Configuration of system events which are to trigger relay switching.</li> </ul>

### 3.1.1.1 System :: Basic settings

The screenshot shows the 'System :: Basic settings' configuration window. The 'Archive settings' section is highlighted with a red circle. The 'Pre-arm time' is set to 0 / 1 Minutes. Other settings include 'Follow-up time' at 1 Minute, 'System language' at German, and various recording limits and deletion times.

Setting	Value	Unit
Follow-up time	1	Minutes
System language	German	
Default output	Kamera 1	
Automatically video output transfer after	0	Seconds
Hard disk size	76319	MBytes
Limit the size of permanent recordings to	100 : 0	Hours : Minutes
Delete permanent recordings after	72 : 0	Hours : Minutes
Limit the size of alarm recordings to	10 : 0	Hours : Minutes
Delete alarm recordings after	96 : 0	Hours : Minutes
Pre-arm time	0 / 1	Minutes / Minutes
Operation at interchange of hard disks	Format unknown hard disks	



Once a hard disk is put in a different MR3140 unit all the data on the hard disk will be automatically deleted after 30 seconds, if this is set up in the device configuration. (It is the standard setting under **Archive settings** → **action when exchanging hard disks**). This is a security mechanism!

For these 30 seconds the HD LED on the front of the device flashes yellow. During this time you can switch the machine off if the data are not to be deleted.

**After 30 seconds the data are irretrievably deleted and are no longer recoverable! The hard disk is automatically adopted by the recorder and prepared for recording. (Exception: the HD is password-protected and this is not stored in the device configuration. In this case the disk will be declined and the HD LED on the device lights red.)**

**We recommend that all hard disks which are to be swapped from one device into another should be routinely formatted in the TTU. In this process the password for the storage device is replaced and any problems with disk adoption in the other unit are avoided.**

Parameters	Description
<b>General settings</b>	
Shut down device if ignition is deactivated	<ul style="list-style-type: none"> <li>▪ If this option is activated the device will be shut down by deactivating the ignition or the other shut down signal. Exception: Existing connections between the PC and the system (through WLAN, Ethernet) will be switched off by the system after cancelling the connection.</li> <li>▪ If the option is disabled, the system will shut down after all processing times, stopping alarm records and after dismantling an established research connection.</li> </ul>
System follow up time	<ul style="list-style-type: none"> <li>▪ After the ignition is switched off the device remains active in the recording mode for this period.</li> <li>▪ Controlled shutdown after this period has elapsed.</li> </ul>
System language	<ul style="list-style-type: none"> <li>▪ Language options for standard names of sensors, cameras and relays.</li> <li>▪ User-defined names are not affected by this setting.</li> </ul>
<b>Video output</b>	
Text insertions in the video output (OSD)	<ul style="list-style-type: none"> <li>▪ Display of text insertions (OSD) through the video OUT on a monitor</li> <li>▪ Additional display of:                             <ul style="list-style-type: none"> <li>▪ Date</li> <li>▪ Time</li> <li>▪ Camera name</li> <li>▪ Activated sensor</li> <li>▪ System events (no camera signal, movement, etc.)</li> </ul> </li> </ul>
Standard version	<ul style="list-style-type: none"> <li>▪ Choice of the camera signal which is to be shown on the external monitor as standard when the MR3140 is switched on.</li> </ul> <p><b>Caution: If you already have activated a camera in the dialogue „Activations“ for displaying, side effects can occur. Only use one of these options.</b></p>
Automatic switching of video output after	<ul style="list-style-type: none"> <li>▪ Activating the checkbox enables the display of                             <ul style="list-style-type: none"> <li>▪ the video sequences from all cameras</li> <li>▪ or multi-views (quad view etc.)</li> </ul>                             changing at regular intervals (beginning with the camera selected under <b>standard output</b>)                         </li> <li>▪ Video footage from up to 12 IP cameras can be displayed at the control monitor.</li> <li>▪ The delay setting for the camera switching at the video output.</li> <li>▪ Continuation of the continuous video output (beginning with the camera signal defined as <b>standard output</b>) after the set time (as defined in <b>automatically video output transfer after</b>) has elapsed.</li> <li>▪ Configuration of the <b>video output</b> display format (in selection tree).</li> </ul>
<b>Archive settings</b>	
Size of hard disk	<ul style="list-style-type: none"> <li>▪ Display the hard disk size (in the MR3140 unit).</li> </ul>
Limit the size of permanent recordings to	<ul style="list-style-type: none"> <li>▪ This allows limiting the recording time in real hours.</li> <li>▪ Time refers to the really recorded time (so not the date or time stamp of the recordings). A value of 24 hours is equal to 24 really recorded hours. Recording is possible about 4 or 5 calendar days.</li> <li>▪ Once this time has elapsed the device automatically over-writes the data – first the oldest ones (FIFO principle).</li> <li>▪ If you do NOT activate this checkbox the device will record data until the hard disk capacity is full. After reaching this limit automatic over-writing of the oldest data takes place.</li> </ul>

Delete permanent recordings after	<ul style="list-style-type: none"> <li>▪ Sets the time value after which the data in the ring archives have to be deleted. This calendrical value represents the maximum storage duration of the data in the ring archives.</li> <li>▪ A value of 24 hours is equal to one calendrical day – even if the value ,Limit the size of... recordings to' isn't reached the oldest data will be over-written automatically.</li> <li>▪ If this checkbox is not activated, automatic over-writing of the oldest data will be started if the capacity of the archives or the disk or the value , Limit the size of... recordings to' (if activated) is reached.</li> </ul>
Limit the size of alarm recordings to	<ul style="list-style-type: none"> <li>▪ This allows limiting the recording time in real hours.</li> <li>▪ Time refers to the really recorded time (so not the date or time stamp of the recordings). A value of 24 hours is equal to 24 really recorded hours. Recording is possible about 4 or 5 calendar days.</li> <li>▪ Once this time has elapsed the device automatically over-writes the data – first the oldest data (FIFO principle).</li> <li>▪ If you do NOT activate this checkbox the device will record data until the hard disk capacity is full. After reaching this limit automatic over-writing of the oldest data takes place.</li> </ul>
Delete alarm recordings after	<ul style="list-style-type: none"> <li>▪ Sets the time value after which the data in the alarm archives have to be deleted. This calendrical value represents the maximum storage duration of the data in the ring archives.</li> <li>▪ A value of 24 hours is equal to one calendrical day – even if the value ,Limit the size of... recordings to' isn't reached the oldest data will be over-written automatically.</li> <li>▪ If an automatic over-writing of the alarm data isn't desired, this option should be deactivated.</li> </ul>
Pre alarm time	<ul style="list-style-type: none"> <li>▪ Adds video data which were recorded before the alarm event to the data from the alarm period.</li> <li>▪ Determine here how long the period should be.</li> <li>▪ The value entered here must be less than the value in the field <b>Limit the size of...</b> If a larger value is entered this will automatically be reduced to match that entered in the <b>Limit the size of...</b> field.</li> </ul>
Post alarm time	<ul style="list-style-type: none"> <li>▪ Adds video data which was recorded after the alarm event to the data from the alarm period.</li> <li>▪ Determine here how long the period should be.</li> <li>▪ The value entered here must be less than the value in the field <b>Delete alarm recordings after.</b> If a larger value is entered this will automatically be reduced to match that entered in the <b>Delete alarm recordings after</b> field.</li> </ul>
Operation at interchange of hard disks	<ul style="list-style-type: none"> <li>▪ Reject foreign hard disks: HD will be rejected after 30 seconds.</li> <li>▪ Refuse: HD is NOT adopted! HD LED switches to RED, no recording takes place.</li> </ul> <p><b>Caution: If the hard disk is protected with a password and this is not configured for access in the unit, the disk will also not be adopted; the HD LED will also show RED.</b></p>
<b>Additional data</b>	
Record GPS data	<ul style="list-style-type: none"> <li>▪ Start the GPS data recording by activating the checkbox. The activation can only occur after the configuration of the corresponding interface.</li> <li>▪ Configuration of the GPS parameters is done in the GPS dialogue box.</li> </ul>
Record IBIS data	<ul style="list-style-type: none"> <li>▪ Start the IBIS data recording by activating the checkbox (MR3140 unit must be connected to the IBIS bus).</li> <li>▪ Which of the IBIS parameters are recorded by the MR3140 depends on the used IBIS protocol.</li> </ul>

### 3.1.1.2 System :: Time

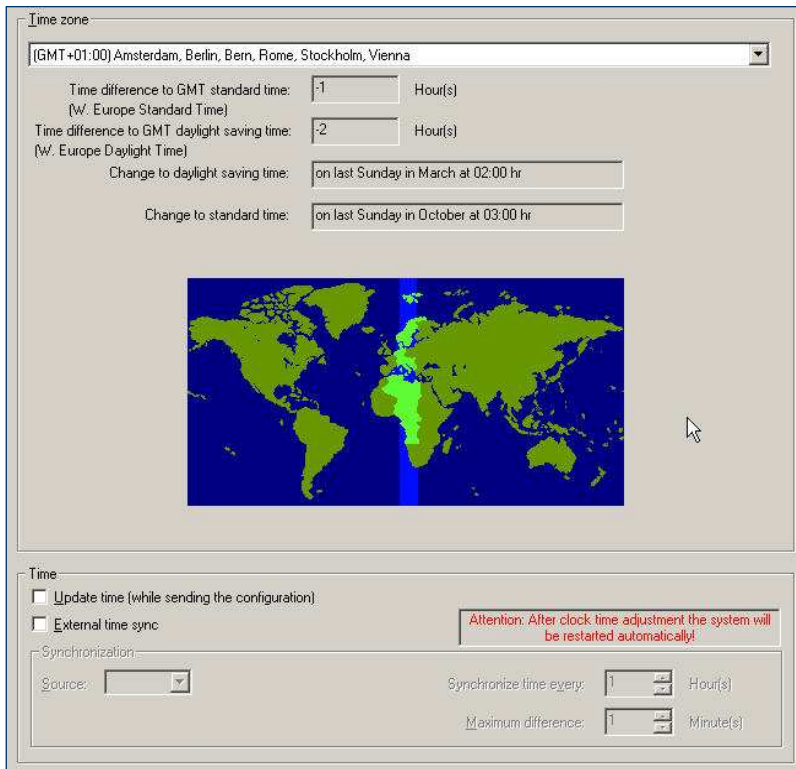

Set your time zone and make the settings for automatic time synchronization in this dialog.



**Caution:** If you reset the time of the MR3140 unit backwards, and you then save the new configuration, all the video footage which is now in the future according to the new time, is automatically deleted!

Field	Description
<b>Time Zone</b>	<ul style="list-style-type: none"> <li>Select a time zone from the listing.</li> <li>The valid properties for that time zone are displayed in the fields below.</li> </ul>
<b>Time</b>	
Update time (while sending the configuration)	<ul style="list-style-type: none"> <li>When the configuration is sent the time of the unit is synchronised with that of the service PC.</li> </ul>
External time sync	<ul style="list-style-type: none"> <li>Regular synchronisation of the unit's time with that of an external source.</li> </ul>
<b>Synchronization</b>	
Source	<ul style="list-style-type: none"> <li>Here you select the external source for synchronising the device time.</li> <li>For this the following conditions have to be fulfilled:                             <ul style="list-style-type: none"> <li>A GPS receiver is connected and configured.</li> <li>The MR3140 is linked to the IBIS bus.</li> </ul> </li> </ul>
Synchronize time every ... Hour(s)	<ul style="list-style-type: none"> <li>This is used to determine the synchronisation cycle.</li> </ul>
Maximum difference ... Minute(s)	<ul style="list-style-type: none"> <li>Enter here the maximum time deviation (in minutes) from the synchronisation source.</li> <li>If when compared, the time deviation is greater than this value then synchronisation takes place. After that the device starts new.</li> </ul>

### 3.1.1.3 System :: Passwords

The length of all passwords and access codes has to be a minimum of 6 and a maximum of 16 characters. There are no passwords in the default factory setting. The codes and passwords are reset when the works settings are reset (see section on updating the device).

The screenshot shows the configuration interface for the TeleObserver MR3140. It is divided into three sections:

- Access code:** A section with a title "TeleObserver® MR3140" and a description: "Access code used for authorisation of connections to this device. The access code may be entered also in the Central Monitoring Software (CMS)." It contains two input fields labeled "Access code:" and "Confirmation:".
- Remote configuration:** A section with a title "Remote configuration" and a description: "This password is used to protect the device configuration. The remote configuration password may be entered also in the Central Monitoring Software (CMS)." It contains two input fields labeled "Password:" and "Confirmation:".
- Data security/Digital Signature:** A section with a title "Data security/Digital Signature" and a description: "This password protects the data against unauthorised access, if the hard disk is installed in external devices." It contains two input fields labeled "Password:" and "Confirmation:".

Name	Description
MR3140	<ul style="list-style-type: none"> <li>▪ The access code is for authorising connections to and from this unit. (needed for access from video analysis software)</li> <li>▪ Repeat the access code in the <b>Confirmation</b> field.</li> </ul>
Remote configuration	<ul style="list-style-type: none"> <li>▪ This password protects the device configuration from changes by third parties.</li> <li>▪ The password is saved in the device after the <b>Send</b> button has been clicked.</li> <li>▪ This password also leads the access to the Web-Interface of the device.</li> <li>▪ The new password is required when reloading the device configuration.</li> <li>▪ Repeat the remote configuration password in the <b>Confirmation</b> field.</li> </ul>
Data security/ Digital Signature	<ul style="list-style-type: none"> <li>▪ The password is used:                             <ul style="list-style-type: none"> <li>▪ to protect the data against unauthorised access if the hard disk is put in a TTU or other external device.</li> <li>▪ to check the digital signature in the video analysis software.</li> </ul> </li> <li>▪ Repeat the password in the <b>Confirmation</b> field for data security.</li> </ul>

### 3.1.1.4 System :: Version

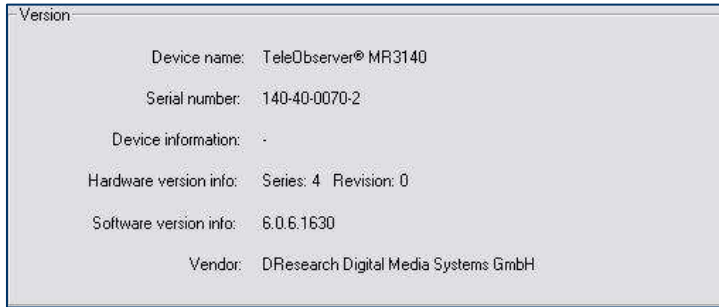

This dialogue box shows the current information of the unit in use. No changes can be made. You should also print out this information and keep it with your documentation. You will need this data for servicing.

### 3.1.1.5 Devices :: Cameras



There are differences in the use of digital and analogue cameras. Please note the following features:

- Analogue cameras are already factory-set.
- Each camera has to be activated for a recording under the dialogue ‚Activations‘ by creating an entry ‚At system start → permanent recording of camera X‘.
- Before analogue cameras can be activated for recording they have to be marked as ‚connected‘.
- **Icons analogue cameras:**



connected, activated for recording



connected, recording not activated



not connected

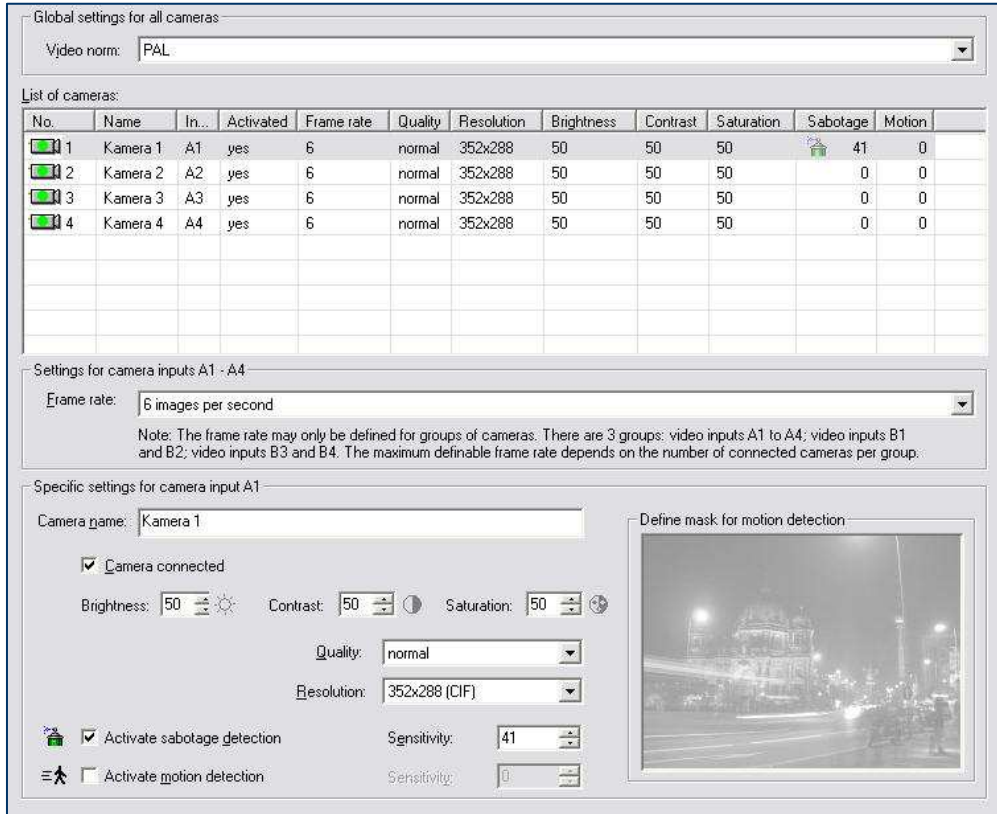

In this dialogue box you determine the cameras which are to be activated for recording and/or for the display on a monitor. To determine the settings select one of the cameras and change the values to suit your requirements.

Global settings	Description
Video norm	<ul style="list-style-type: none"> <li>For selecting the video standard (PAL or NTSC) for data recording.</li> </ul>
List of cameras	<ul style="list-style-type: none"> <li>Lists the analogue cameras and their settings.</li> </ul>
Frame rate	<ul style="list-style-type: none"> <li>Select how many pictures per second are to be recorded (valid for all cameras).</li> <li>Maximum picture rate varies depending on the number of active cameras.</li> <li>Configuration of one or more analogue cameras for the video-OUT reduces the frame rate of the other cameras, as if they were activated for recording!</li> </ul>
Specific settings	Description
Camera name	<ul style="list-style-type: none"> <li>Give the camera a name (max. 50 characters).</li> <li>To achieve accurate identification the name might include reference to the camera's location (Cam1_entrance).</li> <li>Keep names as short as possible so that the whole name is visible on the monitor.</li> </ul>
Camera connected	<ul style="list-style-type: none"> <li>Signals the system, that on the relevant video input a camera is connected physically. All detectors regarding this video input will be activated with this.</li> <li>Only activate this option, if the camera is really connected to the entry, otherwise the device displays error messages (e.g. video signal of a camera is missing).</li> <li>Icon for those cameras which are connected physically to the system, but not activated for recording: </li> <li>After setting the option the camera has to be activated for recording. This setting has to be made in the dialogue 'Activations', by setting a new activation ,At system start → permanent recording of camera X'.</li> <li>Only then appears the icon  for the cameras activated for recording:</li> </ul>

Brightness	<ul style="list-style-type: none"> <li>Enter a brightness value for the selected camera.</li> </ul>
Contrast	<ul style="list-style-type: none"> <li>Here set the contrast for the recordings.</li> </ul>
Saturation	<ul style="list-style-type: none"> <li>Here set the value for saturation.</li> </ul>
Quality	<ul style="list-style-type: none"> <li>Select the quality for the recordings from the activated camera.</li> <li><u>Tip:</u> The lower the quality the lower the storage requirement but also the less detail retained in the video footage.</li> </ul>
Resolution	<ul style="list-style-type: none"> <li>The following resolutions are available for all analogue cameras: 704x288 Pixel (2CIF/field) , 352x288 Pixel (CIF)</li> <li>Formatting of the IP camera is done separately in the camera configuration. (see the camera manual)</li> </ul>
Activate sabotage detection	<ul style="list-style-type: none"> <li>This checkbox activates the camera's sabotage detection function.</li> <li>When the unit registers sabotage activities (the camera lens is covered, dirty or cross fading occurs) then a short message is sent and/or a relay is switched.</li> <li>The video recording itself is not interrupted by sabotage.</li> <li>This feature is available for all connected cameras. Even for those which are not activated for recording.</li> </ul>
Sabotage detection sensitivity	<ul style="list-style-type: none"> <li>Set the sensitivity of the sabotage detection.</li> <li>The value should match the picture content and not be extreme.</li> </ul> <p><u>Tip:</u>  Generally constant pictures → higher value  Highly changing picture contents and lightning conditions → low value  Factory setting: 41</p>
Activate motion detection	<ul style="list-style-type: none"> <li>Marking the checkbox activates motion detection for the camera.</li> <li>Motion detection can trigger various actions: e.g. alarm recording or relay switching</li> </ul>
Motion detection sensitivity	<ul style="list-style-type: none"> <li>Setting the sensitivity of the motion detection.</li> <li>The value should match the picture content and not be extreme.</li> </ul> <p><u>Tip:</u>  Generally little movement in picture → higher value  Lots of movement in picture → low value  Factory setting: 10</p>
Define mask for motion detection	<ul style="list-style-type: none"> <li>Motion detection can be deactivated for selected areas of the picture by setting a mask (privacy zones).</li> <li>Click the picture areas to add or remove them from the masked area.</li> <li>Those areas not monitored for movement detection are shown semi-transparent.</li> </ul>



### 3.1.1.6 Devices :: IP-Cameras















There are differences in the use of digital and analogue cameras. Please note the following features:

- At first each digital camera has to be set under the dialog ‚IP-Camera‘.
- Each camera has to be activated for a recording under the dialogue ‚Activations‘ by creating an entry ‚At system start → permanent recording of camera X‘.
- IP cameras need not to be activated explicitly as ‚connected‘.
- Sabotage and/or motion detection isn’t yet possible by using the system with digital cameras.

▪ **Icons digital cameras:**

-  connected, activated for recording
-  connected, recording not activated
-  connected, only usable for display

List of IP cameras:

No.	Name	Activated	Type	Camera URL
 IP 1	IP Kamera 1	yes	AXIS	http://10.32.200.10
 IP 2	IP Kamera 2	yes	AXIS	http://10.32.200.8
 IP 3	IP Kamera 3	yes	AXIS	http://10.32.200.6
 IP 4	IP Kamera 4	no	AXIS	http://10.32.200.4
 IP 5	IP Kamera 5	no	AXIS	http://10.32.200.10
 IP 6	IP Kamera 6	no	AXIS	http://10.32.200.8
 IP 7	IP Kamera 7	no	AXIS	http://10.32.200.6
 IP 8	IP Kamera 8	no	AXIS	http://10.32.200.4
 IP 9	IP Kamera 9	no	AXIS	http://10.32.200.10
 IP 10	IP Kamera 10	no	AXIS	http://10.32.200.8
 IP 11	IP Kamera 11	no	AXIS	http://10.32.200.6
 IP 12	IP Kamera 12	no	AXIS	http://10.32.200.4

Camera-specific settings

Camera name:

Camera type:

Camera URL:

In this dialogue box you activate the IP cameras which are to be recorded. Please note that we are dealing here with the basic integration parameters of the network cameras.

Network cameras are usually set up using their own web interface. Parameters - such as picture format, quality, colour saturation, frame rate, contrast etc. - have to be configured there as a separate operation.

Name	Description
List of IP cameras	<ul style="list-style-type: none"> <li>▪ The list contains all cameras as well as basic settings. Detailed configuration of IP cameras is done in their own setup.</li> </ul>
<b>camera specific settings</b>	
Camera name	<ul style="list-style-type: none"> <li>▪ Give the selected camera a name (max. 50 characters).</li> </ul>
Camera type	<ul style="list-style-type: none"> <li>▪ Select the type of IP camera.</li> <li>▪ Those camera types currently supported by the software are: <b>AXIS</b>, <b>MOBOTIX</b> and <b>UNKNOWN</b> (manual entry of an http-URL).</li> </ul>
Camera URL	<ul style="list-style-type: none"> <li>▪ The <b>Camera URL</b> field is divided into two.                             <ul style="list-style-type: none"> <li>▪ The first part: Enter the IP address where the camera can be reached in the network.</li> <li>▪ Latter part (camera type <b>UNKNOWN</b>): Enter the HTTP-URL of the IP camera. When called up on the above URL, the camera must provide an MPEG stream (MIME-Typ Multipart, 8-bit) with length data in the header. <b>(E.g. Axis: axis-cgi/mjpg/video.cgi?showlength=on)</b></li> </ul> </li> <li>▪ One completed field is sufficient to accurately identify the IP camera in the network.</li> </ul>
Open address....	<ul style="list-style-type: none"> <li>▪ Click on the <b>Connect</b> button to open your PC's standard browser and create a connection to the IP camera.</li> <li>▪ Possibility to check if the camera can be reached and make camera-specific amendments to the settings.</li> <li>▪ To configure the IP camera's parameters via the browser the cameras and the workstation have to be located in the same network segment.</li> </ul>



**Please note: For IP cameras, the camera configuration must be set so that the MR3140 is set as a "guest" and gets access to the camera without having to provide access data. Otherwise with some cameras (e.g. AXIS 209 FD) recording is not possible.**

### 3.1.1.7 Devices :: Detectors

When a detector is triggered the MR3140 unit can respond specifically to particular (predetermined) events (according to preset actions). Up to 6 external detectors can be linked to the unit’s digital inputs **IN1** to **IN6**. These can be switches or sensors of any kind (light beams, motion detectors, temperature sensors, etc.).

In addition so-called **virtual detectors** can be set up and configured. These indicate events which occur within the device. Such detectors can be activated by, for example a rail media coupler and/or by the analogue cameras’ motion detection function. By selecting **Detector** in the tree structure, the appropriate dialogue box opens. This shows factory-settings for each detector.

Activated detectors are shown with the detector number at the bottom of the screen. Each activation of an external detector is indicated on the control monitor. In addition, when an alarm recording is activated a popup window appears for a short time showing the detector names. The status of the individual detectors is shown in **Vision** if there is a connection to the relevant unit. The individual trigger/event can be assigned an action, which will be executed by the system when the trigger/event is unleashed.

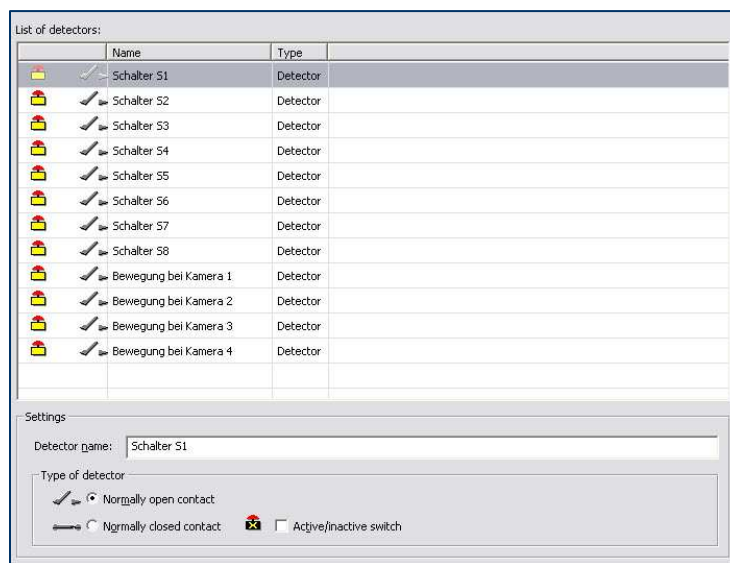

Name	Description
List of detectors	<ul style="list-style-type: none"> <li>List of detectors and their settings.</li> <li>Highlight the detector whose properties are to be configured.</li> </ul>
Detector name	<ul style="list-style-type: none"> <li>Here you can change the detector names (default names <b>Switch S1</b> to <b>Switch S6</b>)</li> </ul>
Detector type	<ul style="list-style-type: none"> <li>All detectors can be assigned one of the following detector types: <b>opener, closer or block lock</b>.</li> <li>When the block lock is activated external events from the detectors are not evaluated and no actions are triggered.</li> </ul>

**3.1.1.8 Devices :: Relays**



Relays which are to be switched by the recorder can be connected to its digital outputs.

Settings have not been entered for each relay in the factory. Change these to suit your requirements by selecting each entry.

Name	Description
List of relays	<ul style="list-style-type: none"> <li>Contains a list of all available relays.</li> </ul>
Relay name	<ul style="list-style-type: none"> <li>You can change the relay names (default names <b>Output 1</b> to <b>Output 4</b>).</li> </ul>

**3.1.1.9 Devices :: Audio**



Recording of audio data can be activated for this device. Therefore a corresponding device has to be connected to the ,Audio' connector (microphone).

Activate the record only if it is really necessary. The recording of the data is uncompressed. It creates large volumes of data.

**3.1.1.10 Connectors :: GPS**

The device supports the connection of an external GPS receiver for receiving GPS data. This can be connected either via the COM1 port or the Ext. Devices (COM4 = RS485) port. This has to be configured in the SystemManagement module as follows:

- In the options on the main window select the **Connections – GPS** entry.
- Select the **COM 1** or **COM4** (RS485) port.
- Click the **Save** button on the toolbar to set the default settings.

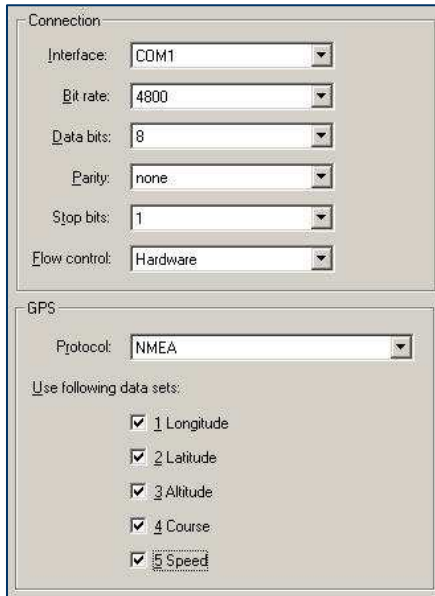

<b>Bitrate: 4800</b>
<b>Data bits: 8</b>
<b>Parity: none</b>
<b>Stop bits: 1</b>
<b>Flow control: none</b>
<b>Protocol: NMEA</b>
<b>GPS databases are not activated</b>

Field	Description
<b>Connection</b>	
Interface	<ul style="list-style-type: none"> <li>▪ Select the unit's <b>COM1</b> or <b>Ext. Device</b> (=COM4=RS485) interface to which the GPS receiver is to be connected.</li> <li>▪ <b>COM1</b> is recommended as this is a direct connection.</li> <li>▪ If a rail media coupler is connected to the unit then the <b>Ext. Device</b> port is not available.</li> </ul>
Bit rate	<ul style="list-style-type: none"> <li>▪ Set the maximum bit rate which can be used for transmission between the GPS receiver and the unit's COM port.</li> </ul>
Data bits	<ul style="list-style-type: none"> <li>▪ Number of bits which can be transmitted in a data packet.</li> </ul>
Parity	<ul style="list-style-type: none"> <li>▪ Shows whether error checking is carried out or not.</li> </ul>
Stop bits	<ul style="list-style-type: none"> <li>▪ Number of stop bits between two transmitted data packets.</li> </ul>
Flow control	<ul style="list-style-type: none"> <li>▪ Shows how the data flow between the serial interface and GPS receiver is controlled.</li> </ul>
<b>GPS</b>	
Protocol	<ul style="list-style-type: none"> <li>▪ Set the protocol used by the GPS receiver.</li> <li>▪ The <b>NMEA</b> protocol is supported.</li> </ul>
Use following data sets	<ul style="list-style-type: none"> <li>▪ Mark the parameters, whose values will be recorded for a subsequent search and displayed in <b>Vision</b> in live pictures.</li> </ul>

### 3.1.1.11 Connectors :: Network

Gateway:

List of network interfaces:

Name	IP address	Net mask	Broadcast
eth0	10.32.41.31	255.255.0.0	10.32.255.255

IP settings:

IP address:

Net mask:

Boot protocol:

The network configuration of the device is determined in this dialogue box. Changes to the settings can only be made by authorised specialists with thorough network knowledge.

Incorrect settings may mean that the device can no longer be reached!

**Standard IP: 192.168.0.1**

Field	Description
Gateway	<ul style="list-style-type: none"> <li>Enter the IP address of the gateway.</li> <li><b>Note:</b> The IP addresses of the recorder and gateway have to be in the same network sector.</li> <li>The gateway enables communication and data transmission between computers which are in different networks or in a linked external communication system.</li> <li>Enter the IP address of the unit if all the connections to be made to the MR3140 are in its network sector or no gateway is available.</li> </ul>
List of the network interfaces	<ul style="list-style-type: none"> <li>All the network adapters installed in the MR3140 are shown here.</li> <li>Click and highlight to display the parameters of a network interface.</li> </ul>
IP address	<ul style="list-style-type: none"> <li>Shows the IP address of the highlighted network adapter.</li> </ul>
Net mask	<ul style="list-style-type: none"> <li>Shows the current network mask.</li> </ul>
Boot protocol	<ul style="list-style-type: none"> <li>Not used</li> </ul>

 Each device in a network has to get a unique address - otherwise there will be IP address conflicts, a connection to the device is then not possible.

If a connection is impossible, please empty the ARP cache of the computer using the **arp -d** command (through console).

**3.1.1.12 Video output :: MultiView**

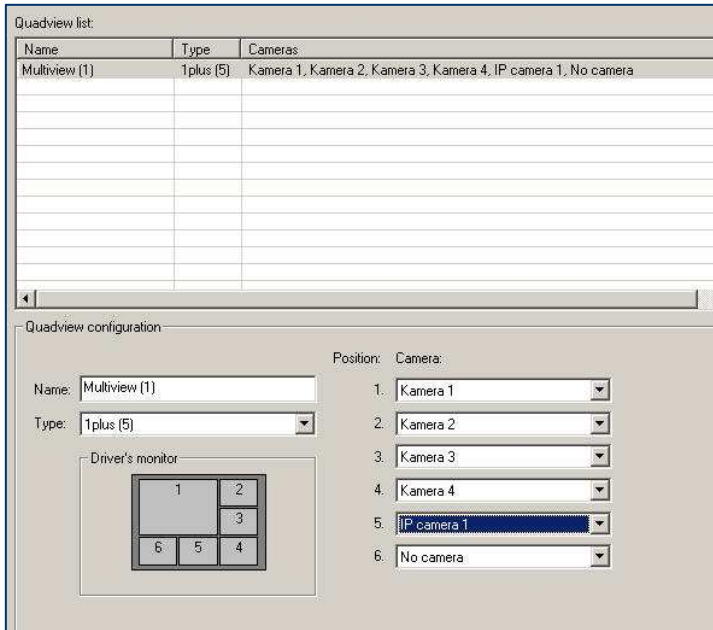

Store new viewing formats here by pressing the NEW button and configure the display as you want.

Several types of views are available for selection:

- Quad - 4 cameras
- Nona - 9 cameras
- 1plus (5) - 6 cameras
- 1plus (7) - 8 cameras

A maximum of 9 camera signals can be displayed in a view.



**QuadView with the analogue cameras 1-4 is set as standard. However several views can be defined which can be activated for a switching at the control monitor.**

**If you want to set one of these views as the start up view set this under System :: basic settings in the “video output” field → “Standard output“.**

**3.1.1.13 Video output :: Transfer order**

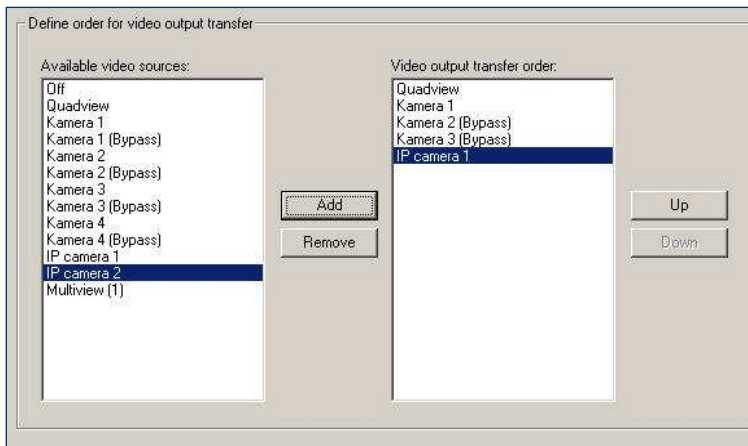

Here you determine the switching sequence. You can select from all the camera entries, even the IP cameras which are not activated for recording.

Bypass means that the camera signal goes directly from video-IN to video-OUT. This setting relieves the recorder but means no overlay of additional information is possible.



**The switching time, after which the view is switched to the next camera picture or multi-view format is determined by the “Video output” → “...switch after...” field in the basic settings.**

**The automatic transfer order stops at source OFF. After that you have to switch manually. For this reason the source OFF shouldn't be admitted into the video output transfer.**

### 3.1.1.14 Activations

From version 6 activations can be defined and configured. The available detectors are up to the third level by a logical AND operator (incl. the state defined for the detector) combinable. This feature provides in everyday use a maximum of flexibility to cover the various requirements.

Following activations are configured:

Detector	Operation
Schalter 51	Alarm recording of camera 'IP Kamera 2'
Schalter 51	Alarm recording of camera 'Kamera 4'
Schalter 51	Alarm recording of camera 'Kamera 3'
Schalter 51	Alarm recording of camera 'Kamera 2'
Schalter 51	Alarm recording of camera 'Kamera 1'
Schalter 51	Alarm recording of camera 'IP Kamera 3'
Schalter 51	Alarm recording of camera 'IP Kamera 1'
At system start	Permanent recording of camera 'Kamera 1'
At system start	Permanent recording of camera 'Kamera 4'
At system start	Permanent recording of camera 'Kamera 3'
At system start	Permanent recording of camera 'Kamera 2'

Configure activation

Select a detector and chose the operation which is to be carried out if the detector is activated.

If detector:

+ AND\_detector:

+ AND\_detector:

Operation:

Details for 'Alarm recording'

Source (Audio/Video):

Field	Description
List	<ul style="list-style-type: none"> <li>▪ Listing of the detectors and corresponding defined actions.</li> </ul>
<b>Configure activation</b>	
Selection detector	<ul style="list-style-type: none"> <li>▪ Available detectors (system start, digital inputs, motion detectors of the cameras) to which an activation can be allocated.</li> <li>▪ For the digital inputs additionally the state (On, Off) is selectable.</li> <li>▪ Activation of additional detectors, which can be combined with shown detectors and their condition through a logically AND operator.</li> </ul>
Operation	<ul style="list-style-type: none"> <li>▪ An action which is defined for the existence of a constellation set under ‚Configure activations‘:                             <ul style="list-style-type: none"> <li>▪ Start permanent recording of a camera (definable)</li> <li>▪ Start alarm recording of a camera (definable)</li> <li>▪ Switch camera to video out (definable through details)</li> <li>▪ Finish alle alarm recordings</li> <li>▪ Switch relays (definable through details)</li> <li>▪ Send SMS</li> <li>▪ Switch device off</li> <li>▪ Videoausgabe weiterschalten</li> </ul> </li> </ul>
Details	<ul style="list-style-type: none"> <li>▪ For some defined actions here are additional configuration options available (for the most no further details are available).</li> <li>▪ With the setting ‚Switch camera to video out‘ it's possible to define different actions for activation and deactivation of the detector and to switch the signals of all cameras. If analogue cameras are configured as not connected, even a circuit through the Bypass is possible. If the camera is physically connected to the video input, the video signals will be redirected directly (without going through the processor) to the video output.</li> <li>▪ By choosing the option ‚Off‘ a black image is generated and displayed.</li> </ul>



**Attention: Never configure the system in the way that a shut down will be performed if the ignition signal is on (Ignition = ON and Action = Switch off device). This leads to an undefined state where the system will continuously reboot. As a result the system can not be reset and has to be shipped to the manufacturer.**

The list of available detectors will be continuously expanded in upcoming versions. The logical combination of detector conditions and the definition of an action to be done represent a broad scope for the representation of various configurations. For example you can interrupt and restart the recording in the ring archives via a „Pause“ button – without switching off the device.

### 3.1.1.15 System events

System events are actions or status changes which are activated by the device or other components connected to it. All system events are displayed on the control monitor. Also, when an event occurs a blue popup window appears for a short time.

Furthermore when a system event occurs the recorder can switch relays. The current status of the system events is shown in the **Vision** selection options (under **detectors**) if there is a connection to the relevant device.

Indicate alarm recordings by relays: Output 1

Indicate system failure 1 by relays: Output 2

Indicate system failure 2 by relays: No signalling

IBIS device type: IBIS display Address: 1

If in case of a system event a text message is to be sent or the event is to be considered as a system failure then activate the corresponding field with a double click.  
The function will be deactivated with a second double click.

List of system events:

Name	Te...	System failure 1	System failure 2	IBIS status reply
Alarm archives are 80% full		<input type="checkbox"/>	<input type="checkbox"/>	"0" System operational (no error)
Alarm recording activated				"0" System operational (no error)
Active/inactive switch activated				"0" System operational (no error)
Hard disk error		<input checked="" type="checkbox"/>	<input type="checkbox"/>	"3" System malfunction (destination ...
No hard disk found		<input checked="" type="checkbox"/>	<input type="checkbox"/>	"0" System operational (no error)
IBIS bus failure		<input checked="" type="checkbox"/>	<input type="checkbox"/>	"0" System operational (no error)
System ready for use				"0" System operational (no error)
Missing video signal of a camera		<input checked="" type="checkbox"/>	<input type="checkbox"/>	"3" System malfunction (destination ...
GPS failure		<input type="checkbox"/>	<input type="checkbox"/>	"3" System malfunction (destination ...
Camera sabotaged		<input type="checkbox"/>	<input type="checkbox"/>	"3" System malfunction (destination ...
Alarm archives are 60% full		<input type="checkbox"/>	<input type="checkbox"/>	"0" System operational (no error)
Unspezifizierter Systemfehler				"3" System malfunction (destination ...

In order to configure the sending of text messages in this dialog, a modem and a text message number must be defined first in dialog "Modem".

Field	Description
Indicate alarm recordings by relays	<ul style="list-style-type: none"> <li>▪ If alarm video sequences are to be recorded from at least one camera, select the relay to be activated.</li> <li>▪ The relay remains activated as long as there is active alarm recording including during the post-alarm period.</li> <li>▪ Relays which have already been switched by detector activations cannot indicate any alarm recording and are therefore not included in the list of options.</li> </ul>
Indicate system failure 1 by relays	<ul style="list-style-type: none"> <li>▪ Select the relay to be activated if a system fault occurs.</li> <li>▪ The system event which is to be treated as fault 1 can be determined in the <b>System events</b> list.</li> <li>▪ Relays which have already been switched by detector activations cannot indicate any system fault and are therefore not included in the list of options.</li> </ul>
Indicate system failure 2 by relays	<ul style="list-style-type: none"> <li>▪ Select the relay to be activated if a system fault occurs.</li> <li>▪ The system event which is to be treated as fault 2 can be determined in the <b>System events</b> list.</li> <li>▪ Relays which have already been switched by detector activations cannot indicate any system fault and are therefore not included in the list of options.</li> </ul>
IBIS device type	<ul style="list-style-type: none"> <li>▪ Select with which IBIS telegrams the system shall communicate with the IBIS Master. The system works conform to the IBIS standard VDV300.</li> <li>▪ The system can be configured as 'Cancelation device', 'Stop announcement' or 'Display' (telegrams 020/120, 030/130 or 070/170). The IBIS standard does not provide an own device type for video systems.</li> </ul>
Address	<ul style="list-style-type: none"> <li>▪ Insert here the video systems address within the IBIS bus. Make sure that these addresses will not be awarded twice! Inform about the current configuration and the specific of the used IBIS system.</li> </ul>
List of system events	<ul style="list-style-type: none"> <li>▪ Shows all system events.</li> <li>▪ Mark the appropriate event by double clicking to assign a system fault.</li> </ul>

System event	Description
Alarm archives full	<ul style="list-style-type: none"> <li>▪ The unit's archives are 100% full.</li> <li>▪ No more alarm data can be stored.</li> <li>▪ If necessary archive the data and then release the archive.</li> </ul>
Alarm archives 80% full	<ul style="list-style-type: none"> <li>▪ The unit's archives are 80% full.</li> </ul>
Alarm recording active	<ul style="list-style-type: none"> <li>▪ The recorder is recording alarm footage from one or more linked cameras.</li> </ul>
Block lock active	<ul style="list-style-type: none"> <li>▪ The recorder's block lock is activated.</li> </ul>
Hard disk defect	<ul style="list-style-type: none"> <li>▪ The hard disk in the recorder is defective.</li> <li>▪ Data recording is no longer possible.</li> </ul>
No hard disk found	<ul style="list-style-type: none"> <li>▪ No hard disk has been inserted into the recorder.</li> </ul>
IBIS bus fault	<ul style="list-style-type: none"> <li>▪ IBIS signals are not being received.</li> <li>▪ Possible causes: <ul style="list-style-type: none"> <li>▪ no available signal</li> <li>▪ signal cannot be read or other fault.</li> </ul> </li> </ul>
System ready for operation	<ul style="list-style-type: none"> <li>▪ The recorder is ready for operation, i.e. it is connected to the power supply and has completed the booting process.</li> </ul>
Video signal from a camera is missing	<ul style="list-style-type: none"> <li>▪ One of the cameras connected to the unit is not delivering a video signal.</li> </ul>
GPS fault	<ul style="list-style-type: none"> <li>▪ GPS reception is disrupted.</li> <li>▪ Possible causes:: GPS aerial is faulty or not installed or there is no GPS reception (e.g. in a tunnel).</li> </ul>
Camera sabotaged	<ul style="list-style-type: none"> <li>▪ One of the cameras connected to the unit has been sabotaged.</li> </ul>
Alarm archives 60% full	<ul style="list-style-type: none"> <li>▪ The unit's archives are 60% full.</li> </ul>
Unspecific system failure	<ul style="list-style-type: none"> <li>▪ There is no miscellaneous system failure.</li> </ul>

### 3.2 The web interface of the system

The system provides a web interface, through which system information can be shown as well as certain configurations can be done. The web interface is available through an existing network connection between PC and the system by using a web browser– therefore insert the IP address of the system in the address bar of your browsers.

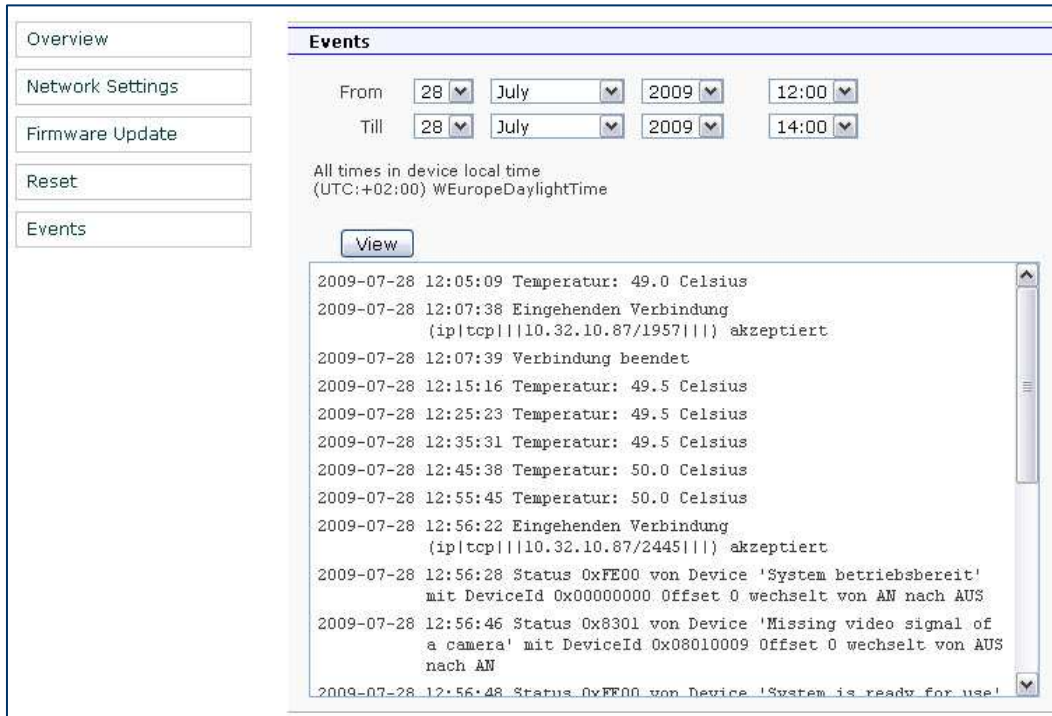

Settings	Description
Overview	<ul style="list-style-type: none"> <li>Information (device type, version of the firmware, value temperature shutdown level)</li> </ul>
Network settings	<ul style="list-style-type: none"> <li>Configuration of IP address, subnet mask and gateway</li> </ul>
Firmware Update	<ul style="list-style-type: none"> <li>Possibility to update the system firmware. The corresponding update packages are provided by DRResearch or your system integrator.</li> </ul>
Reset	<ul style="list-style-type: none"> <li>Here you restart the system with the actual settings.</li> <li>In the case of serious system errors the system can be reset to the configuration, which has been set during an update with the update tool (either the default settings or the configuration of the customer)</li> </ul>
Events	<ul style="list-style-type: none"> <li>Filter option for the log file of the system.</li> <li>Extracts or the complete log file of the system can be displayed and copied.</li> </ul>

## 4 Relevant comments on the daily operation

The following relates to the use of the system in everyday life. Please note, that failure to comply with the instructions can really shorten the life of the system and/or individual components. In the worst case it can lead to irreparable damage, which is not covered by the warranty or guarantee.

### 4.1 Power supply and shutdown of the systems

It is important to ensure that the system is connected to a continuous power supply with correct value. Voltage fluctuations have to be intercepted by appropriate measures (e.g. UPS). Switching on and off is only allowed through the ignition contact or the key switch. Via this ignition signal the system is controlled booted up and shut down and so it saves data integrity and the full operational readiness.



**The system must never be switched off by hard shutdown. This shortens the lifetime of the disk and leads to damage. Furthermore it is possible that hard shutdown leads to inconsistent data, because the archive structures could get damaged.**

Especially in the case of retrofitting of railed vehicles there is often the problem that no ignition signal is available. An appropriate boot up and shutdown signal (i.e. ignition) signal has to be provided. The technical staff has to be informed that the system has to be shut down controlled through a main switch before they shut down the vehicle and all its systems. Only then the main switch can be operated.

### 4.2 Hold-back time of the permanent recordings versus data privacy

During the permanent recordings the system automatically draws up an internal new archive for each camera at every full hour. Determine in the configuration how long the recordings in the ring archives shall be hold back at least (factory-set not added). A value of 48-72 hours as hold-back time for the records in the ring archives is usual. Synchronous data privacy requires in the most European countries, that the permanent recordings must not hold-back for more than 48 hours. It is obvious that these requirements are in conflict with each other.

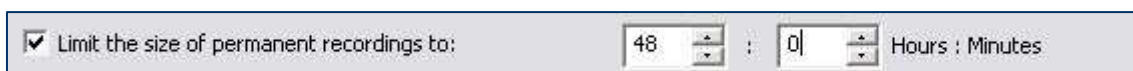

The above made setting "Limit the size of permanent recordings to:" = 48 hours guarantees, that no video data are available which are older than 48 hours. The priority of data privacy is higher, which leads to automatic deletion of the oldest sequences from the 47<sup>th</sup> hours. So there are no full 48 hours in the ring archives – but perhaps only 47,xx hours!

### 4.3 Shutdown behaviour of the system

#### 4.3.1 Shutdown behaviour during permanent and alarm recordings

The device distinguishes between two sources for a shutdown requirement (trigger for controlled shutdown): Shutdown requirement through ignition (shut down signal) and also shutdown requirement from another source (HD lock or detector e.g. input or motion detection). Depending on the triggering source the behaviour differs in normal operation and at a current alarm recording as follows:

	<b>Trigger: ignition (ignition or other shutdown signal)</b>	<b>Trigger: other sources such as HD lock, detector, digital input</b>
<b>Behaviour in normal operation:</b>	<ul style="list-style-type: none"> <li>If the shutdown requirement is not cancelled, the system processes the configured system follow-up time (which can be 0 seconds). If the requirement will not be cancelled (restarting the device) the system shuts down.</li> </ul>	<ul style="list-style-type: none"> <li>The device shuts down. This behaviour has priority over the system follow-up time.</li> </ul>
<b>Behaviour in alarm recordings:</b>	<ul style="list-style-type: none"> <li>As long as an alarm is active, the device records into the alarm archives (only in the case of longer fitting detectors, not for pulse detectors e.g. an alarm button).  If there is already a shutdown requirement and the device is in the system follow-up time, the follow-up time will be "freezed" during the alarm and post-alarm recordings.</li> <li>After finish of the alarm the device records into the alarm archives for the configured follow-up time.</li> <li>After the post-alarm duration the device processes the configured system follow-up time (which can be 0) or continues a „frozen“ system follow-up time.</li> </ul> <p>If the shutdown requirement hasn't been cancelled during this time, the device shuts down. If further alarms occur in this period the follow-up time will be frozen again – the above described process takes place again.</p>	<ul style="list-style-type: none"> <li>The device shuts down. This behaviour has priority over alarm or post-alarm recordings and the system follow-up time.</li> </ul>



**A shutdown requirement for the system using HD-lock switch, detectors and/or digital switch inputs has priority over a currently ongoing alarm recording!**  
**If an existing shutdown requirement will be cancelled before the end of the alarm (system will be switched on again), the device doesn't shut down – but turns into the normal operation mode after processing the alarm and post-alarm time.**

### 4.3.2 Shutdown behaviour during data research



During a data research at the device (through connection via Ethernet and/or WLAN) the system only shuts down when all connections between device and analysing software have been finished. This is a security mechanism which ensures data integrity and spares the lifetime of the disks.

So a shutdown of the device isn't possible during a data access – neither through a switch at a digital input, nor through switching off the ignition. The condition is shown by the LED on the device (HD-LED = OFF, LINK-LED = GREEN).

The data research at the device through an existing network connection should only happen for reasons of controlling.

The staff at the headquarter should therefore be aware that the connections to the video systems always have to be closed or finished – otherwise it's not possible to switch off the systems in the vehicles.

Basic settings / behaviour	Checkbox 'Ignition shuts down the device immediately' is ACTIVATED	Checkbox 'Ignition shuts down the device immediately' is DEACTIVATED
<b>Behaviour during active alarm recording</b>	<ul style="list-style-type: none"> <li>Device shuts down immediately.</li> </ul>	<ul style="list-style-type: none"> <li>Device shuts down after the alarm as well as the post-alarm and system follow-up time are finished.</li> </ul>
<b>Behaviour during an update</b>	<ul style="list-style-type: none"> <li>Device doesn't shut down (automatic restart after the update is finished).</li> </ul>	<ul style="list-style-type: none"> <li>Device doesn't shut down (automatic restart after the update is finished).</li> </ul>
<b>Behaviour during a data research</b>	<ul style="list-style-type: none"> <li>Device shuts down after finishing all network connections with the analysing software.</li> </ul>	<ul style="list-style-type: none"> <li>Device shuts down after finishing all network connections with the analysing software.</li> </ul>

### 4.3.3 Influencing of the recording during data research

In the normal operating mode the system records into the archives. Factory-set the device is so configured that all recordings will be interrupted when data research at device takes place. This is the case when there is a connection between the analysing software on a PC and the system (direct connection via Ethernet cable or external WLAN module). Temporary gaps of recording in the video data can be reasoned by an access to the data archives.

This is factory-set for performance optimization and can later be changed. Indeed these changes can't be made through the configuration of the system – but have to be asked for by the manufacturer.

#### 4.4 Overheat protection: temperature shutdown level of the system

The system is equipped with an automatic overheating protection which ensures that damages caused by overheating will be excluded. If the device's internal temperature reaches a value of +55°C the system shuts down controlled to protect the disk and further system components.



**Please note that the internal temperature of the system can be up to 15°C higher than the ambient temperature (because of the heat generation of the components).**

**Note therefore essential the mounting instructions in this document. Avoid installations where heat can build up. Select the installation place so that adequate air circulation is provided and the developing heat can be derived through the heatsinks of the device.**

**Deactivating of the 55°C overheat protection isn't recommended but possible. Here is the shutdown level at a value of 70°C – not 55°C. For reasons of security the configuration of the temperature shutdown level isn't possible through the configuration settings. The relevant settings can be done during an update of the systems with the update tool.**

**Please note that the operation of the system components (e.g. HDD) is recommended by their respective manufacturers only up to 55°C.**

#### 4.5 Default configuration for factory reset

By starting a reset via the web interface of the system or if the system can't load the actual configuration because of an error the fallback configuration will automatically be loaded. It's possible to define the factory or the system (the customer specific) configuration as fallback configuration.

##### **Actual system configuration:**

During a reset a copy of the actual configuration of the system will be loaded. This ensures that the individual system settings will be maintained after reset, too.

##### **Factory configuration:**

During a reset the standard configuration – delivered by the manufacturer – will be loaded. At this previously made settings in the system will be lost. The only exception: The IP address of the device will not be reset – so that the system afterwards can be achieved without reconfiguring the service PC.



**Please note that the fallback configuration can only be defined during an update with the DResearch update tool or by loading a specific configuration file. This can be made available by the manufacturer on request.**

## 5 Update & Reset, maintenance, problem analysis and technical support

### 5.1 Update of the device via the update tool

A firmware update of the system can be made through the web interface of the device or with the DResearch update tool. With the update tool offered by DResearch a MR system can be provided easy and convenient with the latest firmware. If it is a system of type MR3040 the tool migrates the system to type MR3140, too.

Make a network connection between a PC and the system through the Ethernet interface. Therefore use the crosslink Ethernet cable if you want to migrate a MR3040 system (the network adapter of the PC has to be configured to half duplex 10/mbit). Otherwise it's possible to use a usual Ethernet cable. Start the update tool and follow the instructions in the manual of the update tool.

### 5.2 Update and Reset of the device via the web interface



**If your unit is from type MR3040 please contact directly our staff members. This device has to be reconfigured to a MR3140 with the help of a specific upgrade/update. Please contact the manufacturer directly for realizing the migration of the device.**

**The device can be returned to its factory settings with a "Reset". This can be required if the unit is no longer reachable because inappropriate parameters have been set. Please note that the WebUI is protected, if you have set a configuration password.**

- Connect the unit to your PC via the LAN interface (using a patch cable).
- Switch the service-PC and the MR3140 unit on.
- Copy the update file which you have received from your system integrator/manufacturer into a folder on the service laptop.
- Start a web browser on the service laptop (IE, Firefox, etc.)  
In the browser's address line enter "http://<IP address of the recorder>"  
(e.g. "http:// 192.168.0.1") – the recorder interface will opened.
- Click on the **Firmware-Update** or **Reset** button and follow the instructions on the screen.



**If the factory settings are restored the device parameters are returned to their factory settings. Apart from the network settings, (IP address, gateway and subnet mask) all previously set parameter values are overwritten.**

**The IP address won't be returned to their factory settings, because the device wouldn't be available after the update.**

**A Reset should only be carried out in an absolute emergency (e.g. if the unit can't handle correctly with the configuration settings and all physical connection faults have been ruled out).**

### 5.3 Maintenance, cleaning and care of the system

You have purchased a system which works largely without maintenance. Depending on the type and kind of installation it will still require external cleaning of the unit. When doing so please follow these instructions:

- Clean the external case with just a soft dry cloth.
- Under no circumstances should the unit be dipped in water.
- Never use solvents and/or cleaning fluids!
- Except for occasional function checks and cleaning of the case and the external connections no further care is necessary.

Checking the functionality of the device has to be carried out at predetermined intervals. Since this is a security system which is part of a larger security infrastructure it is subject to particular maintenance guidelines. Irrespective of these, as the manufacturer we recommend the following checks be carried out once every 6 months:

- **Check all connections, cables and plugs on the unit.**
- **Clean the case with a soft cloth (without solvent).**
- **Check the configuration with the "SystemManagement" CMS module.**
- **Check the recording with the "ImageFinder" CMS module or with the ImageFinder NX.**
- **Check the live pictures with the "Vision" CMS module.**



**The hard disk is a sensitive element of the system. To ensure continuous, problem-free function we recommend checking the disk every 3 months.**

**Incorporate this function check in your service plans.**



## 5.5 Technical support by the manufacturer

If you have questions about your DResearch product we recommend that you first read through the product documentation. You have purchased a top quality product which generally works without servicing. The units are tested several times by DResearch in the test laboratory in order to supply you with a perfect, flawless product. If your unit suddenly does not work perfectly please first ensure that other sources of error can be definitively ruled out.

A detailed listing of frequently asked questions and associated answers you will find on our website [www.dresearch.de](http://www.dresearch.de) in the FAQ area.

### Please check carefully before making the support inquiry:

- Have you followed all the advice in the manual?
- Are all the plugs and sockets properly and firmly connected to the unit?
- Can the recorder be switched on?
- Are you absolutely sure you have ruled out all other sources of error?

### If you need technical support please contact our support team by email ([support@dresearch.de](mailto:support@dresearch.de)) giving them the following information:

- Precise name and serial number of the device.  
The serial number is on the bottom of the device. Without the serial number the support request cannot be processed.
- Invoice number / Delivery note number
- What firmware version is your MR3140 using? (To find the firmware version go to the setup menu and open the **Version** dialogue box.)
- What version number of the **Central Monitoring Software** are you using? Details of this will be found on the title page of the launcher.
- What operating system are you using?
- At what point or in what application does the problem or error report occur? Please note down the exact wording of the error message displayed.
- A description of the problem and what actions were being performed before the problem appeared.

Our support team will process your request as quickly as possible and assist you in resolving the problem.



**If it is necessary to return an item this is always to be negotiated with the manufacturer beforehand. Only pre-agreed returns are processed. You will be provided with a special (RMA) code before you return the shipment.**

**The manufacturer takes no responsibility for any damage incurred during transportation or for the costs of transportation insurance.**

**No 'cash on delivery' or 'carriage forward' shipments will be accepted.**

## 6 Technical data of the MR3140

Dimensions			
Dimensions (H x B x D)	80 mm x 238 mm x 240 mm		
Weight	3.4 kg		
Environmental conditions			
Parameter	minimum	maximum	
Temperature			
Operation (Recording)	0 °C	+55 °C / + 70°C	
Extended range	-20 °C	+70 °C	
Storage	-40 °C	+70 °C	
Humidity	10 %	90 % (not condensing)	
Mechanical loading			
Vibration (operation)	1 G (5 – 500 Hz)		
Shock (all axes)	3 G		
Electrical connected load			
Parameter	minimum	typical	maximum
Power supply	+ 12 V DC	+ 24 V DC	+ 32 V DC
Power supply to cameras	12 V/1.5 A		
Power consumption			
System standby mode (no recording, permanent positive, no ignition)	< 0,5 W		
System pause mode (no recording, permanent positive, no ignition)	< 18 W		
Recording without cameras	max. 18 W		
Recording inc. cameras	max. 40 W		
Digital Video Subsystem			
Parameter	minimum	typical	maximum
Picture storage rate @ PAL @ NTSC	1		25 pictures/s 30 pictures /s
Picture storage rate IP cameras	1	50 pictures /s	200 pictures /s
Max. storage duration	48 hours with 4 pictures /s and 160 GB hard disk		
Video interfaces			
Video inputs			
Connectors:	BNC		
Number:	4 x BNC, composite (PAL/NTSC)		
Resolution:	analogue: CIF, 2CIF, digital: data from IP camera, dynamic control of frame rates depending on load, 8 Bit Luminance, 8 Bit Chrominance		
Impedance:	75 Ohm		
Signal level (peak-peak):	1 V +/- 3 dB		
Video input IP network			
Ethernet LAN 1	realization: RJ45, 100 Mbit		
Video output			
Connectors:	BNC		
Number:	2 x BNC, composite (PAL/NTSC), same signal		
Output:	1 x video source, quad view, video switching of all cameras		
Impedance:	75 Ohm		
Signal level (typical, peak-peak):	1 V		

<b>Audio interface</b>		
<b>Audio input</b>		
Connectors:	D-Sub-9 socket (female)	
Number:	1	
Signal level (max., peak-peak):	2,8 V (+2 dBu), 0,5 V (-13 dBu) with input amplifier	
Input impedance:	>10 kOhm	
Frequency response (+/-3 dB):	100 Hz ... 10 kHz	
<b>Digital interfaces</b>		
<b>Digital inputs</b>		
Connectors:	D-Sub-25-socket (female)	
Number:	6	
Input level:	Low: 0 ... 3 V High: 6 ... 34 V	
<b>Ignition input</b>		
Number:	1 (differential)	
Differential input levels:	Low: 0... 3V High: 6... 34V	
<b>Digital outputs</b>		
Connectors:	D-Sub-25-socket (female)	
Number:	4 relays (SPDT)	
Capacity:	60 V DC, 125 V AC, 500 mA	
<b>Picture data transmission</b>		
<b>Communication links</b>	<b>Transmission rate</b>	<b>Bandwidth</b>
LAN/Ethernet	25 pictures/s	100 Mbit/s
WLAN	25 pictures/s	54 Mbit/s
<b>Other interfaces</b>		
<b>RS232</b>	D-Sub-9-socket (male)	
<b>RS485</b>	D-Sub-25- socket (male)	
<b>Ethernet</b>	1 x RJ45 (LAN 1), 100 Mbit as service interface	
<b>IBIS</b>	D-Sub-25- socket (male)	
<b>LED</b>	4 (status conditions: off, red, yellow, green)	

### 7 Technical drawing

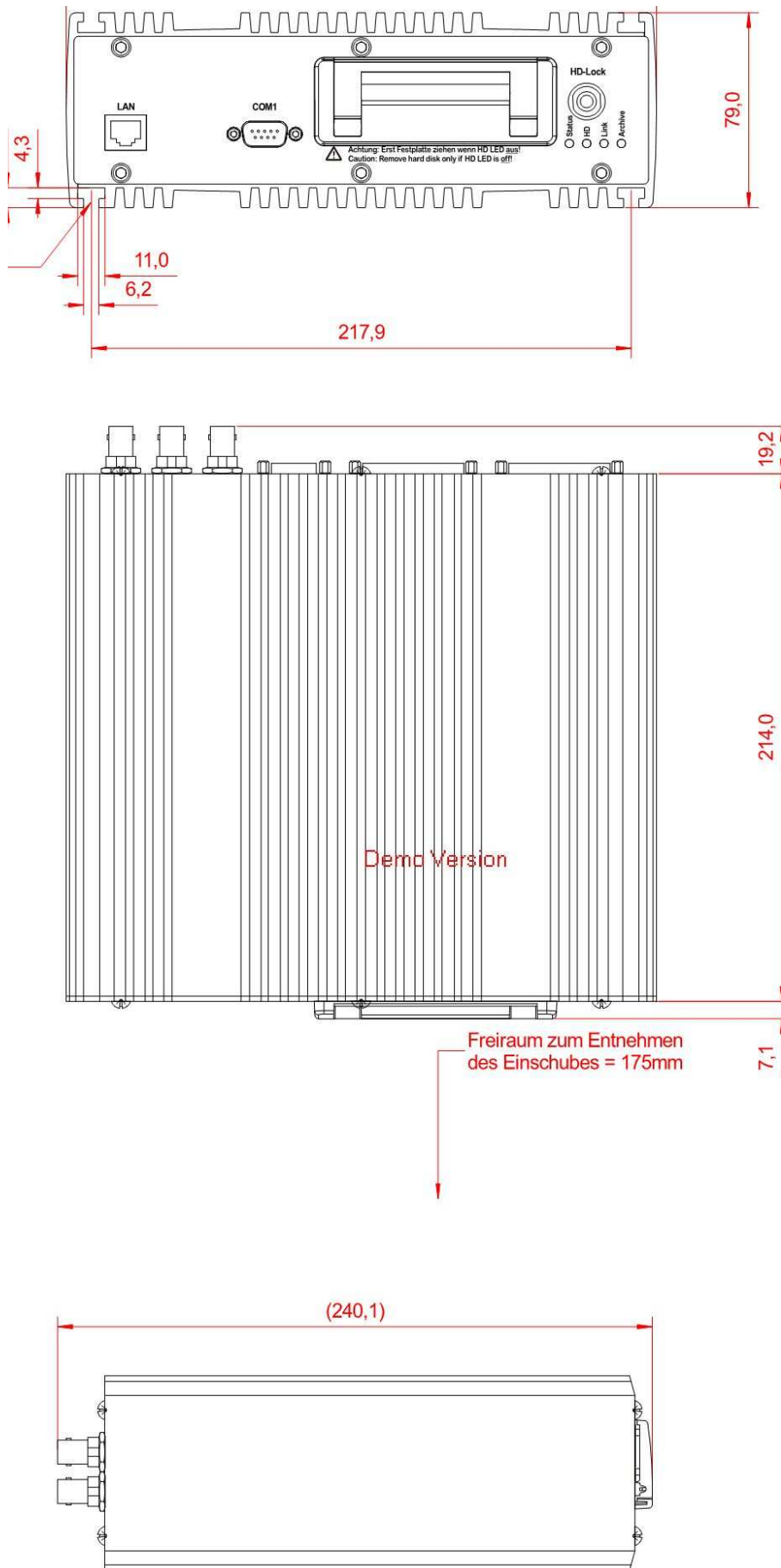

## 8 Abbreviations

<b>AC/DC</b>	Alternating Current/Direct Current
<b>CAN</b>	Controller Area Network
<b>CIF</b>	Common Intermediate Format
<b>CMS</b>	Central Monitoring Software
<b>CMU</b>	Central Monitoring Unit
<b>DSL</b>	Digital Subscriber Line
<b>EMC</b>	Electromagnetic Compatibility
<b>GPI</b>	General Purpose Input
<b>GPIO</b>	General Purpose Input/Output
<b>GPS</b>	Global Positioning System
<b>HD</b>	Hard Disk
<b>HDD</b>	Hard Disk Drive
<b>IBIS</b>	Integrated on-Board Information System
<b>ISDN</b>	Integrated Service Digital Network
<b>LAN</b>	Local Area Network
<b>LED</b>	Light-emitting Diode
<b>NTSC</b>	National Television Standards Committee
<b>PAL</b>	Phase Alternated Line
<b>RMA</b>	Return of Material Authorization
<b>RMC</b>	Rail Media Coupler
<b>SMS</b>	Short Message Service
<b>SPDT</b>	Single-Pole Double Throw
<b>TTU</b>	TeleObserver Transfer Unit
<b>UMTS</b>	Universal Mobile Telecommunications System
<b>UPS</b>	Uninterruptible Power Supply
<b>UTC</b>	Universal Time Code
<b>WLAN</b>	Wireless Local Area Network

**Annotations:**



DResearch is member of ZVEI, BHE and VDS

**DResearch  
Fahrzeugelektronik  
GmbH**

Otto-Schmirgal-Str. 3  
10319 Berlin, Germany  
Tel +49 (30) 515 932 -0  
Fax+49 (30) 515 932 -77

E-Mail: [contact@dresearch.de](mailto:contact@dresearch.de)  
<http://www.dresearch.de>

*All brand names, product names and trade names are trademarks or registered trademarks of their respective holders.*

*DResearch Fahrzeugelektronik GmbH © 2011*